



Compressor  
Voltage Code : TZ

**TAG2516Z**

Low Temp. Commercial (BP)

400V 3~ 50Hz / 440V 3~ 60 Hz

R452A / R404A / R448A / R449A

AGB2513ZTZ

Conditions	Frequency	Nominal Cooling Capacity		Sound Power ISO3745 / ISO 3743-1
		Watts	BTU/h	
EN12900 / R452A	50 Hz / 60 Hz	1763 / 2123	6012 / 7241	77 dBA
EN12900 / R404A	50 Hz / 60 Hz	1917 / 2414	6538 / 8231	77 dBA
EN12900 / R448A	50 Hz / 60 Hz	1492 / 1879	5089 / 6408	77 dBA
EN12900 / R449A	50 Hz / 60 Hz	1492 / 1879	5089 / 6408	77 dBA

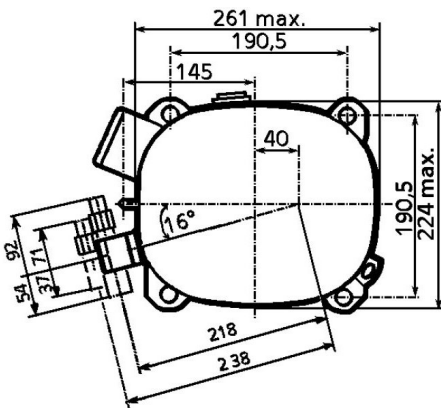
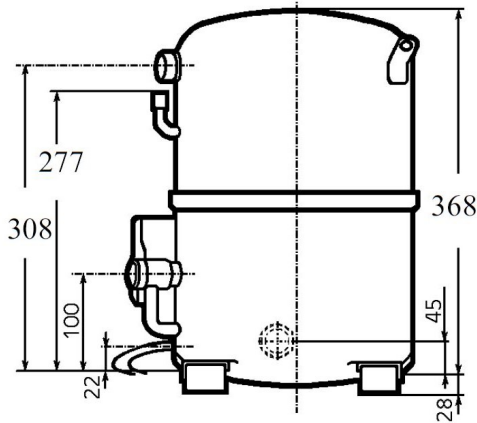

<b>Displacement (cc)</b>	112,5
<b>Net Weight (Kg)</b>	43.0
<b>Oil Quantity (cc)</b>	1760.0
<b>Oil Type</b>	Polyolester
<b>Expansion Device</b>	Capillary_Tube/Expansion_Valve
<b>Cooling</b>	Fan
<b>Main Winding (Ohm)</b>	4.6
<b>Current</b>	
RLA (A)	4.8   4.9
MCC (A)	9.5   9.4
LRA (A)	42   42
<b>Electrical Equipment</b>	TRI
<b>Overload</b>	Interne
<b>Refrigerating connection for</b>	
Suction Tube	22.2 (7/8")
Discharge Tube	15.9 (5/8")
Process Tube	6.35 (1/4")

\* EN12900 : T°Cond. 40.0°C / T°Evap. -35.0°C / T°Return gas temp.. 20.0°C  
T°Subcooling. 0.0K

Certificates :



Note : Tecumseh reserves the right to change information contained in this document without notification.



**Tecumseh**

<b>TAG2516Z</b>	<b>Tension TZ : 400V 3~ 50Hz / 440V 3~ 60 Hz</b>
-----------------	--

Les performances sont données dans les <b>conditions EN12900</b> :	Gaz aspirés :	20.0 °C
Condition Dew	Sous refroidissement :	0.0 K
The performance data are in <b>EN12900 conditions</b> :	Return gas :	20.0 °C
Dew Condition	Subcooling :	0.0 K

<b>50 Hz R452A</b>									
<b>N°2569</b>									
									
4   T condensation	5   T évaporation	(°C)	-40	-35	-30	-25	-20	-15	-10
<b>30</b>	1   P frigorifique	(Watt)	1606	2447	3500	4790	6345	8189	10350
	2   P absorbée	(W)	1417	1770	2153	2548	2937	3301	3622
	3   I absorbée	(A)	3.44	3.75	4.13	4.58	5.10	5.69	6.36
<b>40</b>	1   P frigorifique	(Watt)	1040	1763	2662	3762	5089	6671	8532
	2   P absorbée	(W)	1323	1693	2120	2585	3071	3557	4027
	3   I absorbée	(A)	3.31	3.68	4.13	4.65	5.24	5.91	6.64
<b>50</b>	1   P frigorifique	(Watt)		1114	1853	2758	3855	5169	6726
	2   P absorbée	(W)		1569	2009	2514	3065	3644	4232
	3   I absorbée	(A)		3.50	4.02	4.61	5.28	6.01	6.82
<b>60</b>	1   P frigorifique	(Watt)				1808	2668	3710	4959
	2   P absorbée	(W)				2367	2952	3592	4268
	3   I absorbée	(A)				4.46	5.19	6.00	6.88

<b>60 Hz R452A</b>									
<b>N°2569</b>									
4   T condensation	5   T évaporation	(°C)	-40	-35	-30	-25	-20	-15	-10
<b>30</b>	1   P frigorifique	(Watt)	1945	3006	4278	5777	7517	9515	11786
	2   P absorbée	(W)	1591	2022	2457	2905	3374	3871	4404
	3   I absorbée	(A)	2.95	3.40	3.88	4.38	4.92	5.51	6.16
<b>40</b>	1   P frigorifique	(Watt)	1164	2123	3266	4607	6161	7945	9974
	2   P absorbée	(W)	1312	1839	2364	2895	3440	4007	4603
	3   I absorbée	(A)	2.66	3.21	3.77	4.37	5.00	5.67	6.41
<b>50</b>	1   P frigorifique	(Watt)		1249	2244	3409	4759	6310	8078
	2   P absorbée	(W)		1478	2114	2749	3393	4051	4731
	3   I absorbée	(A)		2.83	3.50	4.20	4.94	5.72	6.56
<b>60</b>	1   P frigorifique	(Watt)				2200	3328	4628	6117
	2   P absorbée	(W)				2419	3181	3951	4738
	3   I absorbée	(A)				3.84	4.70	5.61	6.57

1 = cooling capacity 2 = power input 3 = current 4 = condensing temperature 5 = evaporating temperature

**Nota : Tecumseh se réserve le droit de modifier les informations contenues dans ce document sans préavis.**  
**Note : Tecumseh reserves the right to change information contained in this document without notification.**

© 2021 Tecumseh Products Company  
All rights reserved



**Tecumseh**

<b>TAG2516Z</b>	<b>Tension TZ : 400V 3~ 50Hz / 440V 3~ 60 Hz</b>
-----------------	--

Les performances sont données dans les <b>conditions EN12900</b> :	Gaz aspirés :	20.0 °C
Condition Dew	Sous refroidissement :	0.0 K
The performance data are in <b>EN12900 conditions</b> :	Return gas :	20.0 °C
Dew Condition	Subcooling :	0.0 K

© 2021 Tecumseh Products Company  
All rights reserved

### 50 Hz R404A

**N°2564**

4   T condensation	5   T évaporation	(°C)	-40	-35	-30	-25	-20	-15	-10
<b>30</b>	1   P frigorifique	(Watt)	1734	2618	3714	5045	6636	8510	10691
	2   P absorbée	(W)	1551	1939	2336	2747	3176	3625	4099
	3   I absorbée	(A)	3.53	3.93	4.37	4.86	5.40	5.99	6.62
<b>40</b>	1   P frigorifique	(Watt)	1161	1917	2846	3971	5316	6904	8759
	2   P absorbée	(W)	1439	1873	2319	2780	3258	3759	4285
	3   I absorbée	(A)	3.40	3.87	4.39	4.95	5.56	6.22	6.92
<b>50</b>	1   P frigorifique	(Watt)		1251	2006	2918	4011	5307	6831
	2   P absorbée	(W)		1735	2231	2743	3274	3829	4410
	3   I absorbée	(A)		3.69	4.28	4.91	5.59	6.32	7.09
<b>60</b>	1   P frigorifique	(Watt)			1229	1922	2756	3754	4940
	2   P absorbée	(W)			2061	2627	3214	3824	4463
	3   I absorbée	(A)			4.04	4.75	5.50	6.30	7.14

### 60 Hz R404A

**N°2564**

4   T condensation	5   T évaporation	(°C)	-40	-35	-30	-25	-20	-15	-10
<b>30</b>	1   P frigorifique	(Watt)	2226	3321	4622	6144	7900	9906	12174
	2   P absorbée	(W)	1781	2227	2678	3142	3626	4137	4683
	3   I absorbée	(A)	3.15	3.62	4.12	4.65	5.22	5.83	6.51
<b>40</b>	1   P frigorifique	(Watt)	1430	2414	3573	4923	6477	8248	10252
	2   P absorbée	(W)	1530	2071	2610	3155	3713	4292	4899
	3   I absorbée	(A)	2.89	3.46	4.05	4.66	5.32	6.02	6.78
<b>50</b>	1   P frigorifique	(Watt)		1528	2528	3687	5019	6539	8260
	2   P absorbée	(W)		1749	2397	3043	3696	4363	5051
	3   I absorbée	(A)		3.11	3.81	4.54	5.30	6.11	6.97
<b>60</b>	1   P frigorifique	(Watt)			1505	2455	3549	4798	6218
	2   P absorbée	(W)			1992	2760	3528	4303	5093
	3   I absorbée	(A)			3.36	4.22	5.11	6.04	7.02

1 = cooling capacity 2 = power input 3 = current 4 = condensing temperature 5 = evaporating temperature

**Nota : Tecumseh se réserve le droit de modifier les informations contenues dans ce document sans préavis.**

**Note : Tecumseh reserves the right to change information contained in this document without notification.**



**Tecumseh**

<b>TAG2516Z</b>	<b>Tension TZ : 400V 3~ 50Hz / 440V 3~ 60 Hz</b>
-----------------	--

Les performances sont données dans les <b>conditions EN12900</b> :	Gaz aspirés :	20.0 °C
Condition Dew	Sous refroidissement :	0.0 K
The performance data are in <b>EN12900 conditions</b> :	Return gas :	20.0 °C
Dew Condition	Subcooling :	0.0 K

<b>50 Hz R448A (*)</b>								
<b>N°2899</b>								
4   T condensation	5   T évaporation	(°C)	<b>-35</b>	<b>-30</b>	<b>-25</b>	<b>-20</b>	<b>-15</b>	<b>-10</b>
<b>30</b>	1   P frigorifique	(Watt)	2039	3040	4296	5835	7685	9877
	2   P absorbée	(W)	1675	2038	2416	2816	3241	3696
	3   I absorbée	(A)	3.39	3.81	4.28	4.79	5.36	5.97
<b>40</b>	1   P frigorifique	(Watt)	1492	2341	3410	4729	6326	8231
	2   P absorbée	(W)	1625	2033	2455	2895	3358	3848
	3   I absorbée	(A)	3.36	3.85	4.37	4.94	5.55	6.21
<b>50</b>	1   P frigorifique	(Watt)	981	1679	2564	3665	5012	6633
	2   P absorbée	(W)	1499	1961	2434	2922	3432	3967
	3   I absorbée	(A)	3.19	3.76	4.36	4.99	5.66	6.38
<b>60</b>	1   P frigorifique	(Watt)			1804	2690	3789	5128
	2   P absorbée	(W)			2330	2877	3442	4030
	3   I absorbée	(A)			4.21	4.92	5.67	6.45

<b>60 Hz R448A (*)</b>								
<b>N°2899</b>								
4   T condensation	5   T évaporation	(°C)	<b>-35</b>	<b>-30</b>	<b>-25</b>	<b>-20</b>	<b>-15</b>	<b>-10</b>
<b>30</b>	1   P frigorifique	(Watt)	2588	3785	5232	6946	8945	11246
	2   P absorbée	(W)	1924	2336	2763	3215	3699	4223
	3   I absorbée	(A)	3.13	3.60	4.09	4.63	5.21	5.87
<b>40</b>	1   P frigorifique	(Watt)	1879	2939	4227	5761	7557	9633
	2   P absorbée	(W)	1797	2289	2786	3298	3833	4400
	3   I absorbée	(A)	3.00	3.55	4.12	4.72	5.38	6.09
<b>50</b>	1   P frigorifique	(Watt)	1196	2114	3239	4587	6176	8023
	2   P absorbée	(W)	1511	2107	2701	3299	3910	4544
	3   I absorbée	(A)	2.69	3.35	4.03	4.73	5.47	6.27
<b>60</b>	1   P frigorifique	(Watt)			2306	3464	4841	6454
	2   P absorbée	(W)			2449	3159	3873	4599
	3   I absorbée	(A)			3.74	4.57	5.43	6.34

**1 = cooling capacity 2 = power input 3 = current 4 = condensing temperature 5 = evaporating temperature**

(\*) Veuillez vous référer strictement aux Recommandations d'Utilisation et Bulletins Marketing Tecumseh du fait de la température de refoulement élevée pour les applications LBP.  
 (\*) Due to very high discharge temperature especially on LBP conditions, please strictly refer to Tecumseh Guidelines & Marketing Bulletin when using this refrigerant.

**Nota : Tecumseh se réserve le droit de modifier les informations contenues dans ce document sans préavis.**  
**Note : Tecumseh reserves the right to change information contained in this document without notification.**

© 2021 Tecumseh Products Company  
All rights reserved



**Tecumseh**

<b>TAG2516Z</b>	<b>Tension TZ : 400V 3~ 50Hz / 440V 3~ 60 Hz</b>
-----------------	--

Les performances sont données dans les <b>conditions EN12900</b> :	Gaz aspirés :	20.0 °C
Condition Dew	Sous refroidissement :	0.0 K
The performance data are in <b>EN12900 conditions</b> :	Return gas :	20.0 °C
Dew Condition	Subcooling :	0.0 K

<b>50 Hz R449A (*)</b>								
<b>N°2444</b>								
4   T condensation	5   T évaporation	(°C)	<b>-35</b>	<b>-30</b>	<b>-25</b>	<b>-20</b>	<b>-15</b>	<b>-10</b>
<b>30</b>	1   P frigorifique	(Watt)	2039	3040	4296	5835	7685	9877
	2   P absorbée	(W)	1675	2038	2416	2816	3241	3696
	3   I absorbée	(A)	3.39	3.81	4.28	4.79	5.36	5.97
<b>40</b>	1   P frigorifique	(Watt)	1492	2341	3410	4729	6326	8231
	2   P absorbée	(W)	1625	2033	2455	2895	3358	3848
	3   I absorbée	(A)	3.36	3.85	4.37	4.94	5.55	6.21
<b>50</b>	1   P frigorifique	(Watt)	981	1679	2564	3665	5012	6633
	2   P absorbée	(W)	1499	1961	2434	2922	3432	3967
	3   I absorbée	(A)	3.19	3.76	4.36	4.99	5.66	6.38
<b>60</b>	1   P frigorifique	(Watt)			1804	2690	3789	5128
	2   P absorbée	(W)			2330	2877	3442	4030
	3   I absorbée	(A)			4.21	4.92	5.67	6.45

<b>60 Hz R449A (*)</b>								
<b>N°2444</b>								
4   T condensation	5   T évaporation	(°C)	<b>-35</b>	<b>-30</b>	<b>-25</b>	<b>-20</b>	<b>-15</b>	<b>-10</b>
<b>30</b>	1   P frigorifique	(Watt)	2588	3785	5232	6946	8945	11246
	2   P absorbée	(W)	1924	2336	2763	3215	3699	4223
	3   I absorbée	(A)	3.13	3.60	4.09	4.63	5.21	5.87
<b>40</b>	1   P frigorifique	(Watt)	1879	2939	4227	5761	7557	9633
	2   P absorbée	(W)	1797	2289	2786	3298	3833	4400
	3   I absorbée	(A)	3.00	3.55	4.12	4.72	5.38	6.09
<b>50</b>	1   P frigorifique	(Watt)	1196	2114	3239	4587	6176	8023
	2   P absorbée	(W)	1511	2107	2701	3299	3910	4544
	3   I absorbée	(A)	2.69	3.35	4.03	4.73	5.47	6.27
<b>60</b>	1   P frigorifique	(Watt)			2306	3464	4841	6454
	2   P absorbée	(W)			2449	3159	3873	4599
	3   I absorbée	(A)			3.74	4.57	5.43	6.34

**1 = cooling capacity 2 = power input 3 = current 4 = condensing temperature 5 = evaporating temperature**

(\*) Veuillez vous référer strictement aux Recommandations d'Utilisation et Bulletins Marketing Tecumseh du fait de la température de reflux élevée pour les applications LBP.  
 (\*) Due to very high discharge temperature especially on LBP conditions, please strictly refer to Tecumseh Guidelines & Marketing Bulletin when using this refrigerant.

**Nota : Tecumseh se réserve le droit de modifier les informations contenues dans ce document sans préavis.**  
**Note : Tecumseh reserves the right to change information contained in this document without notification.**

© 2021 Tecumseh Products Company  
All rights reserved