

MODEL NUMBER
ZR160KC/KCE
ZR190KC/KCE
ZP154KCE
ZP182KCE

SPECIFICATIONS	
ES NO.	DESCRIPTION
ES92-155	CONVERSION-METRIC

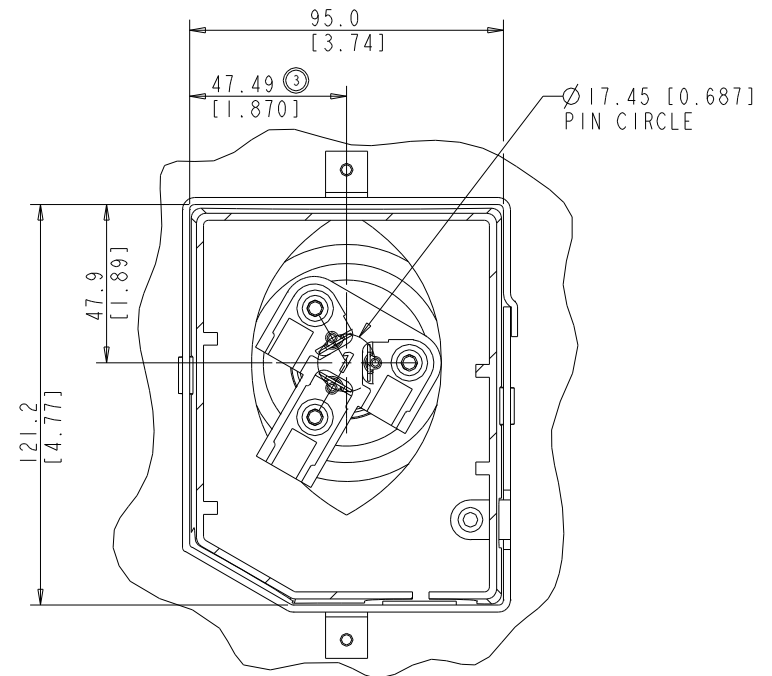
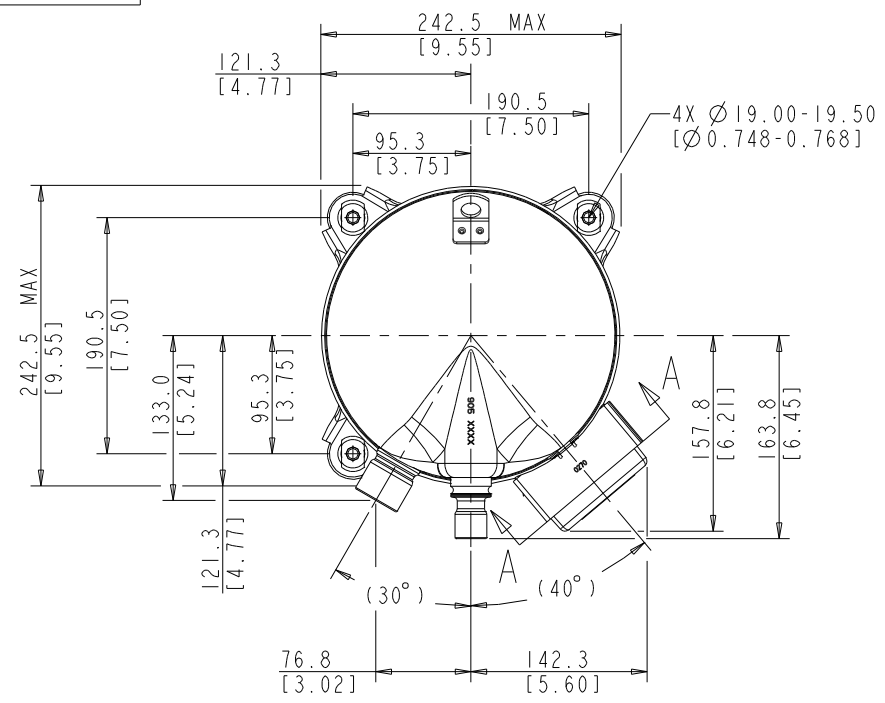

T-BOX LAYOUT
STANDARD
SECTION A - A
SCALE 1:1

- NOTES:
- ① ALL TOLERANCES ±1.5 [0.06] UNLESS OTHERWISE SPECIFIED. DUE TO ACCUMULATED ASSEMBLY TOLERANCES THE LISTED COMPONENTS MAY VARY FROM THE MOUNTING HOLES AS TABULATED.
 - ◇ SUCTION FITTING ±3.0 [0.12]
 - ◇ DISCHARGE FITTING ±3.0 [0.12]
 - ② MOUNTING KIT: 527-0210-00
 - ③ TUBE ENDS MUST BE PLUGGED.

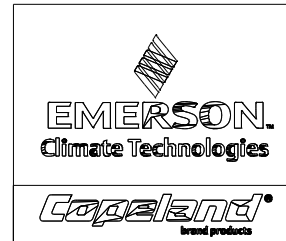
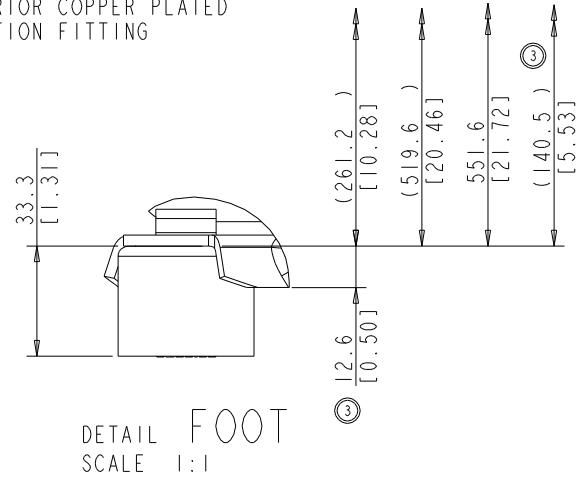
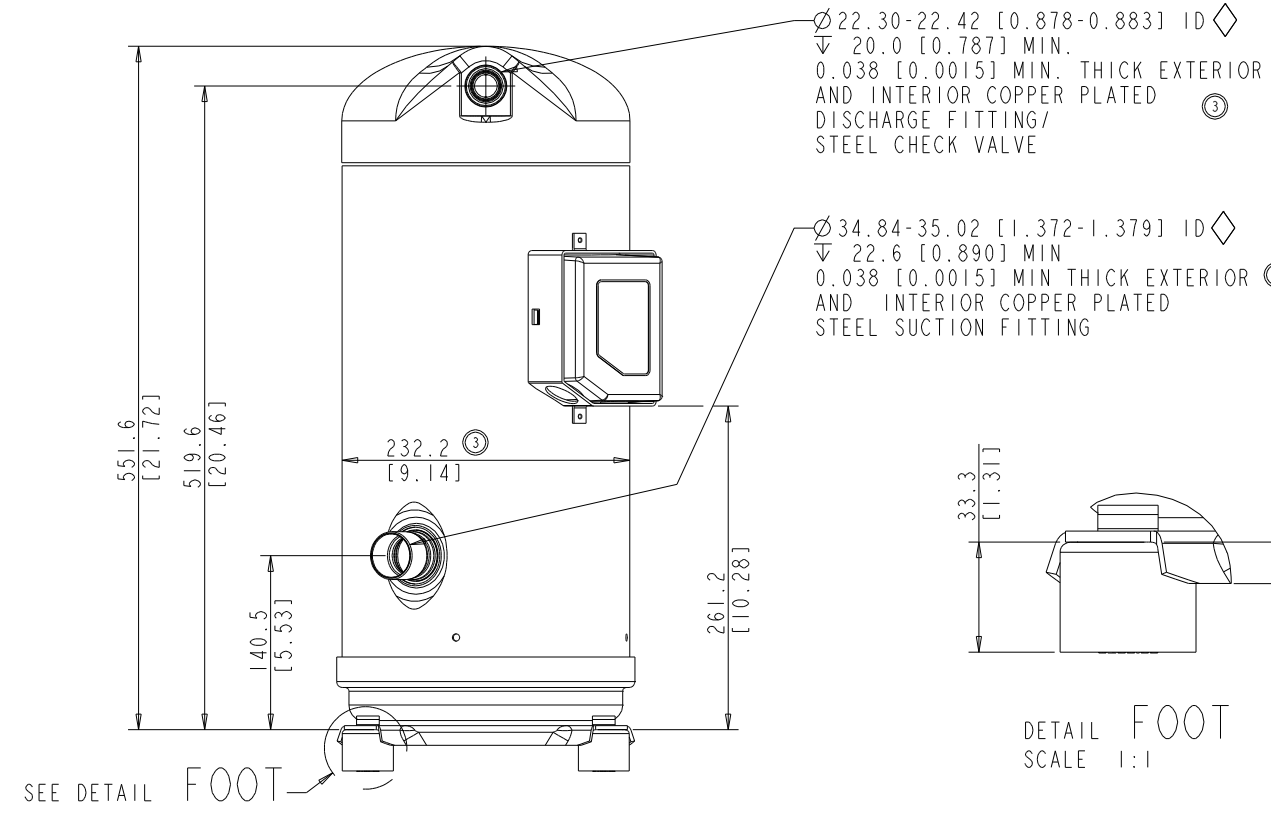
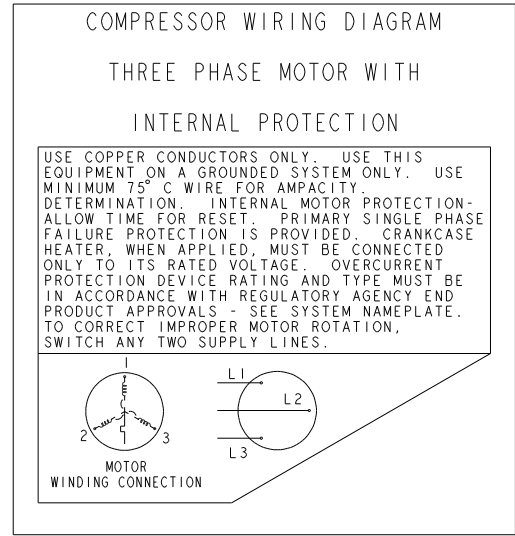

INTERPRET PER ASME Y14.5M-1994 AND EMERSON CLIMATE TECHNOLOGIES, INC. DESIGN STANDARDS DS2002 DO NOT SCALE DRAWING

THIRD ANGLE PROJECTION

CRITICAL PRODUCT CHARACTERISTIC

UNLESS OTHERWISE SPECIFIED DIMENSIONS ARE MILLIMETER OR (INCH)

TOLERANCES:
1-PLACE ± N/A
2-PLACE ± N/A
ANGULAR ± N/A

ECN000821	3	REVISED & REDRAWN	12-06-07	PBM	NJG	KJR
ECN000050	0	RELEASED	03-20-07	JXM	CWK	KJR
ENG NOTICE NO.	REV. NO.	REVISIONS	DATE	BY	CHKD	APPR
15		CONFIDENTIALITY NOTICE				
THIS DRAWING AND INFORMATION CONTAINED HEREIN ARE THE EXCLUSIVE PROPERTY OF EMERSON CLIMATE TECHNOLOGIES, INC. AND SHALL BE RETURNED UPON DEMAND AND SHALL NOT BE REPRODUCED IN WHOLE OR IN PART, DISCLOSED TO ANYONE ELSE OR USED, WITHOUT THE WRITTEN CONSENT OF EMERSON CLIMATE TECHNOLOGIES, INC.						
MATERIAL SPECIFICATION		DRAWN BY	SUPERSEDES DWG. NO. / REV. NO.			
N/A		PBM	497-0518-00 / 2			
		DATE	SCALE	DATE FORMAT:		
		12-06-07	3:8	MM-DD-YY		
TITLE			DRAWING NUMBER	SHEET 1 OF 1	DWG	
REF DWG-WELD COMP ASSM			497-0518-00		4	
					SIZE	