

MODEL NUMBER
ZRT168KC/KCE
ZRT188KC/KCE
ZPT180KCE
ZRUI78KCE

SPECIFICATIONS	
ES NO.	DESCRIPTION
ES92-155	CONVERSION-METRIC

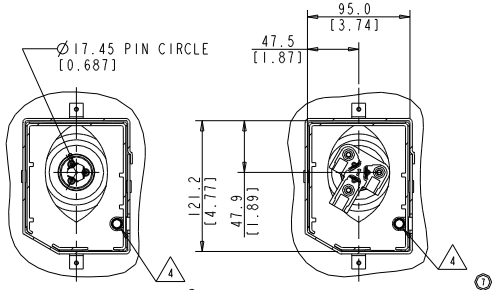

SECTION A-A SCALE 1:2  
SECTION A-A WITH TERMINAL BLOCK SHOWN SCALE 1:2

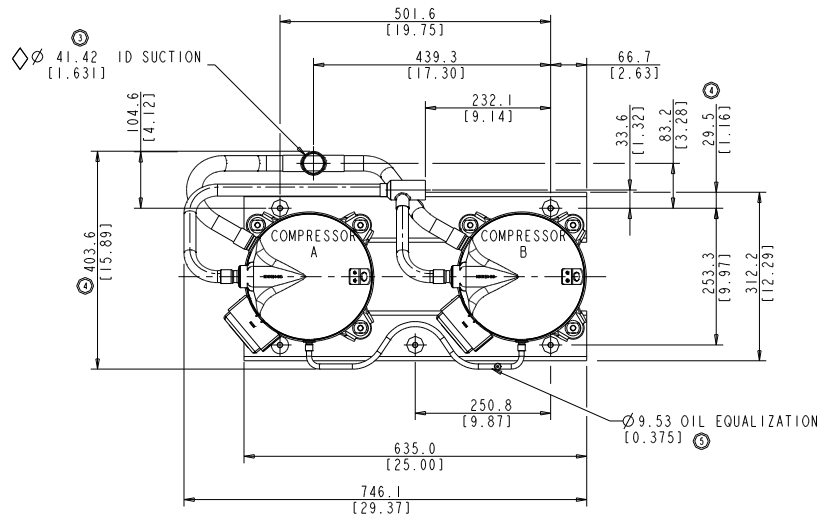
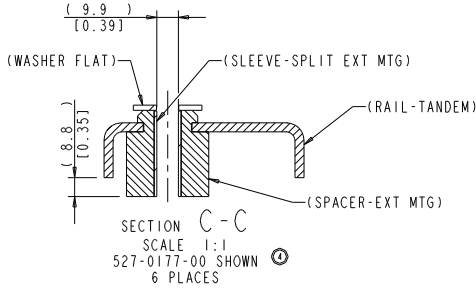

SECTION C-C SCALE 1:1  
527-0177-00 SHOWN 6 PLACES

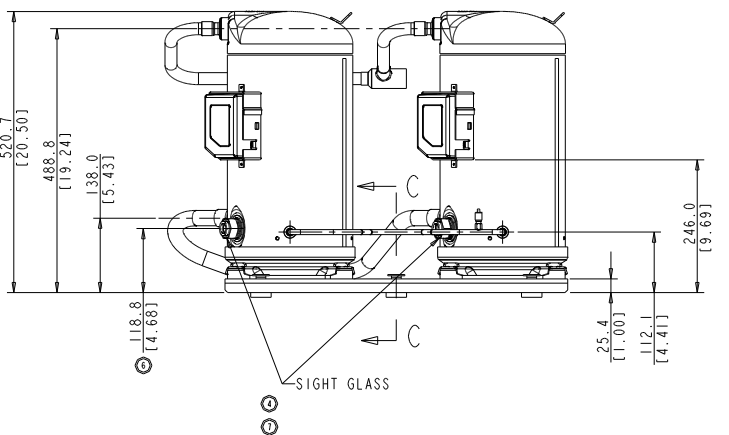
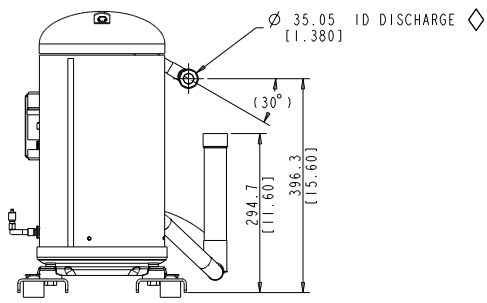

- NOTES:
- ①  $\triangle$  ALL TOLERANCES  $\pm 1.5$  [0.06] UNLESS OTHERWISE SPECIFIED. DUE TO ACCUMULATED ASSEMBLY TOLERANCES THE LISTED COMPONENTS MAY VARY FROM THE MOUNTING HOLES AS TABULATED.
  - $\diamond$  SUCTION FITTING  $\pm 3.0$  [0.12]
  - $\diamond$  DISCHARGE FITTING  $\pm 3.0$  [0.12]
  - 2. MOUNTING KIT: 527-0177-00
  - 3. TUBE ENDS MUST BE PLUGGED.
  - ②  $\triangle$  GROUNDING SCREW AND WASHER PER BOM

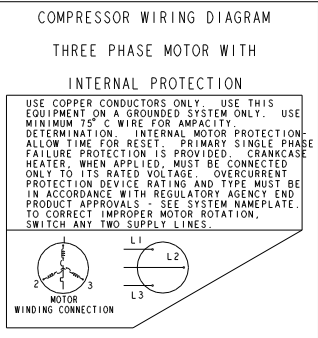

EMERSON Climate Technologies  
Copeland

INTERPRET PER ASME Y14.5M-1994 AND EMERSON CLIMATE TECHNOLOGIES, INC. DESIGN STANDARDS DS2002  
DO NOT SCALE DRAWING

THIRD ANGLE PROJECTION

CRITICAL PRODUCT CHARACTERISTIC  
UNLESS OTHERWISE SPECIFIED DIMENSIONS ARE MILLIMETER OR (INCH) TOLERANCES  
1-PLACE  $\pm$  N/A  
2-PLACE  $\pm$  N/A  
ANGULAR  $\pm$  N/A

ECN001988	7	ADDED NOTES AND CHANGED SIGHT GLASS	01-20-11	LG	MD	VC
ECN001607	6	UPDATE SIGHT GLASS VERTICAL DIMENSION	09-28-09	XHT	LLB	KJR
ECN001607	5	UPDATE DRAWING WITH ASSM-OIL EQUALIZATION	07-31-09	XHT	LLB	KJR
ECN001411	4	ADDED NOTES & SCHEMATIC	11-12-08	PBM	LLB	KJR
ECN000052	3	PICTORIALLY UPDATED STEEL SPACERS	08-08-07	PTM	NJG	KJR
ECN000052	2	ADDED MODEL ZRUI78KCE	06-27-07	PTM	NJG	KJR
ECN000052	1	CHANGED TPTL TUBE ASSEMBLY	01-18-07	PNA	LLB	KJR
ECN000052	0	RELEASED	05-02-04	NJG	CMK	RST

ENG NOTICE NO.	REV. NO.	REVISIONS				DATE	BY	CHD	APPR
15		CONFIDENTIALITY NOTICE							
THIS DRAWING AND INFORMATION CONTAINED HEREIN ARE THE EXCLUSIVE PROPERTY OF EMERSON CLIMATE TECHNOLOGIES, INC. AND SHALL BE RETURNED UPON DEMAND AND SHALL NOT BE REPRODUCED IN WHOLE OR IN PART DISCLOSED TO ANYONE ELSE OR USED, WITHOUT THE WRITTEN CONSENT OF EMERSON CLIMATE TECHNOLOGIES, INC.									
MATERIAL SPECIFICATION		DRWN BY	SUPERSEDES DWG. NO. / REV. NO.						
N/A		NJG	DATE	SCALE	DATE FORMAT:				
			05-02-06	1:4	MM-DD-YY				
TITLE		DRAWING NUMBER		SHEET 1 OF 1		DWG			
REF DWG-WELD COMP ASM		497-0537-04		4		4			