

【公开】

客户名称/Customer: _____

发行编号/NO. : _____

发行日期/DATE: 2023-09-08

全封闭式直流变频压缩机技术规格书

HERMETIC DC INVERTER COMPRESSOR SPECIFICATION

机型/Model: KTF420D64UMVA客户承认栏/Accept Marking:

本规格书从贵公司承认之日起生效，一式贰份。贵公司负责人承认签名之后请返回我公司一份，贵公司保留一份。

*This document will be effective with your authorized signature.
Please return one (1) copy of this form, and keep the other one (1) copy for your records.*

浙江美芝压缩机有限公司

承认/Approved	担当/Drafted

1、适用范围 (Application)

空调器类型 A/C Type	变频驱动冷暖空调器 Inverter Driving Cooling & Heating A/C System
冷媒类型 Refrigerant Type	R32/R410A
最大冷媒充注量 Maximal Refrigerant Charged	4.2Kg Max
电源类型 Power Source	直流变频驱动器 DC Inverter
运转范围 Revolution Range	12 rps ~ 120 rps
安全认证 Safety Approval	CCC、TUV

2、规格参数 (Specification)

压缩机类型 Compressor Type	全封闭旋转式直流变频压缩机 Hermetic Rotary DC Inverter Compressor
汽缸容积 Displacement	41.5 cm ³ /rev.
冷冻机油充注量 Oil Charged	ESTER OIL VG74 1000±15 ml
总重量 (含冷冻机油) Weight (Oil Included)	18.1 ±3% Kg
排气管内径 I. D. of Discharge Pipe	9.8 $\begin{matrix} +0.1 \\ -0 \end{matrix}$ mm
吸气管内径 I. D. of Suction Pipe	16.2 ±0.1 mm

3、电机参数 (Motor Specification)

电机类型 Motor Type	直流无刷电机 DC Brushless Motor
电机极数 Pole Numbers	6 极/Poles
绝缘等级 Insulation Grade	B 级/Grade
绕组阻值 (20°C时) Coil Resistance (at 20°C)	0.63±7% Ω

4、额定性能规格 (Rated Performance Parameters)

额定能力 Rated Capacity	13350 W	≥95%
额定输入功率 (变频器输入侧) Rated Inverter Input Power	3645 W	≤105%
额定输入电流 (变频器输入侧) Rated Inverter Input Current	6.8 A	≤105%
能效比 % COP %	366	≥95%
噪音/NOISE (Sound Power Level)	★ 75 dB(A)	以下 MAX
振动 VIBRATION (切线方向振动实效值)	★ 8 m/s ²	以下 MAX

*Remarks: Rated cop is measured by calorimeter methods of QMA-J50.016 made by Guangdong Meizhi Compressor Co., Ltd. Allowable cop should be more than 95% of the rated cop.

*备注: 额定 COP 根据本公司标准 QMA-J50.016 规定的卡路里方法测试, 允许 COP 应为额定 COP 的 95%以上。

测定条件 (Rating Condition)

回转速度 Revolution	60rps	★60rps
冷凝温度 Cond. Temp.	42.3°C	
蒸发温度 Evap. Temp.	2.8°C	
吸气温度 Return Gas Temp.	12.8°C	
过冷却温度 Liquid Temp.	34.3°C	
环境温度 Ambient Temp.	35°C	
吸排气压力 Ps/Pd		★0.785/2.519Mpa

5、电气配线接线图 (Wire Connection Figure)

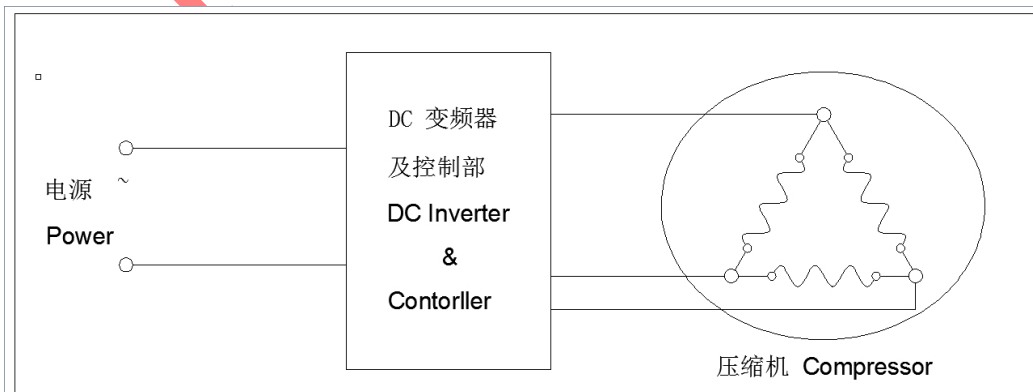

6、一般特性 (Characteristic)

绝缘阻抗 Insulation Resistance	$\geq 20 \text{ M}\Omega$	封入氮气时/Nitrogen Charged
绝缘耐压 Withstanding Voltage	AC1500V-1min	
接地阻抗 Earthing Resistance	0.1 Ω	以下 MAX
残留水分量 Residual Moisture	冷凝法 $\leq 200 \text{ mg}$	
含尘量 Residual Impurities	$\leq 45 \text{ mg}$	

7、系统使用条件 (Limit of System Application)

NO.	项目 Item	标准状况下 Standard Cond.	极限状况下 Limit Cond.	对应冷媒	说明 Note
1	排气压力 Discharge Pressure. (对应的饱和温度)	3.40MPa Max (55°C)	4.28MPa Max (65°C)	R32	10~18rps 运行时 Pd-Ps \geq 0.2MPa 详细压力使用范 围见附纸! See the attached chart of limitation of operation pressure.
		3.28MPa Max (55°C)	4.15MPa Max (65°C)	R410A	
2	吸气压力 Suction Pressure. (对应的饱和温度)	0.55~1.01MPa (-5~10°C)	0.23~1.18MPa (-25~15°C)	R32	
		0.53~0.98MPa (-5~10°C)	0.23~1.15MPa (-25~15°C)	R410A	
3	压缩比 Compressing Ratio	7.5 Max	7.5 Max		
4	电机绕组温度 Motor Coil Temp.	100°C Max	125°C Max	/	
5	排气温度 Discharge Temp.	100°C Max	115°C Max		

8、注意事项 (Application Notice)

- 整个运行过程中无液压缩发生
No liquid refrigerant go back to compressor during the whole time.
- 连续运转时 (包括除霜、除湿) 压缩机底部温度-冷凝器中部温度需大于等于 5°C 以上。
When continuous running (include defrost and dehumidify), compressor bottom temp. subtract condensing temp. should be more than 5°C.
断续运转时压缩机底部温度-冷凝器中部温度需大于等于 0°C 以上
When intermittent running, compressor bottom temp. subtract condensing temp. should be more than 0°C.
当室外温度低于 0°C 时, 推荐压缩机在 26rps 以上转速运行
When the outdoor temp. is below 0°C, compressor's revolution should be operated

over 26rps.

3. 断续运转 30rps 以上，每一周期 5 分钟以上，开 2 分钟以上，停 2 分钟以上；
When intermittent running speed is over 30rps, each cycle should be longer than 5 minutes. (On: over 2 min, Off: over 2 min)
断续运转 30rps 以下，每一周期 8 分钟以上，开 5 分钟以上，停 2 分钟以上；
When intermittent running speed is below 30rps, each cycle should be longer than 8 minutes. (On: over 5 min, Off: over 2 min)
4. 推荐升降速度每秒 1rps
Recommended revolution variation speed is 1rps/second.
压缩机启动至目标转速过程中，必须在 60rps 和 90rps 左右各保持 1 分钟以上运转
When start-up, revolution should be kept at around 60rps and 90rps for at least 1 minute.
在保证油面和没有回液情况下，允许运行 60rps 和 90rps 保持时间在 1 分钟以下
In the condition of ensuring oil level and don't have liquid refrigerant return, the compressor permits to maintain running in 60rps and 90rps within one minute.
当目标转速低于 60rps，必须将转速拉升至 60rps 并保持 1 分钟后，降低至目标转速
When start-up, if the target revolution is less than 60rps, the revolution should be kept at around 60rps for 1 minute before go down to the target revolution.
5. 当电机绕组直接通电加热时，确保绕组温度低于 55°C
Keep the winding Temp. under 55°C, when the compressor winding was heated directly.
6. 高压侧和低压侧压力需保持平衡后才能启动
Pressure should be balanced between high and low pressure side.
7. 运转过程中不能有异常噪音发生
In operation, abnormal noise is not allowed.
8. 推荐除霜转速：90rps 以下
Recommended defrost revolution is less than 90rps.
9. 最大允许倾斜角度：5°
Tilt angle should be less than 5° .
10. 最大三相间电压不平衡电压：2.25%
Voltage unbalance among 3 phases should be less than 2.25%.
11. 当压缩机以下状态时，需确认油面水平
Oil level confirmation should be tested at:
 - a、超负荷、低负荷时；
Overload and low load running;
 - b、冷媒沉积启动时；
Refrigerant soaking starting;
 - c、除霜开始、恢复时；
Defrost starting and resuming;
 - d、超过最长配管时；
Connection pipe over 15m;
 - e、超过最大落差时；
Elevation over 5m;当使用带视窗镜的压缩机进行确认；
Oil level confirmation test performed with side glass compressor:
 - a、在稳定运转状态（包括连续/断续运行），油面需在水平面 B 以上；

At steady running (include continuous or intermittent operation): oil level should be higher than B level.

- b、在启动的 3 分钟以内，油面需在水平面 A 以上；

Within 3 minutes at starting: oil level should be higher than A level.

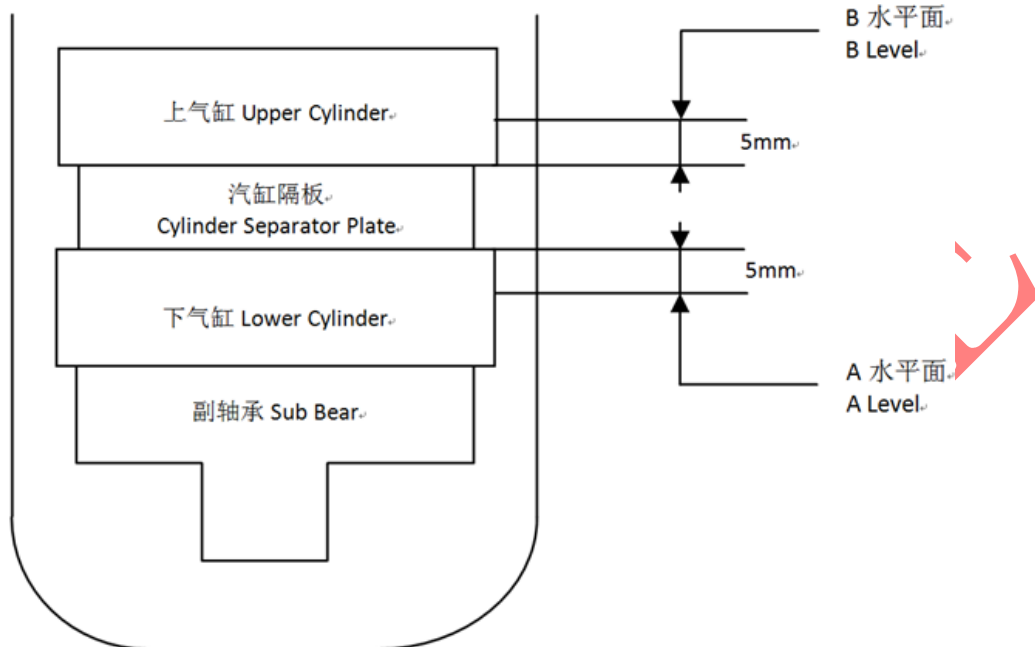

12. 请确认本产品已满足贵司的生产效率及性能下线率要求。

Please confirm that this product can meet your requirements of the productive efficiency and the performance pass rate.

9、其他注意事项 (Other Application Notice)

1. 不要给吐出管、吸入管施加弯曲的力，强制其弯曲。

配管设计时，要考虑产品在始动、运转停止以及运输搬运时的振动应力，不致发生损坏。

推荐各配管许容应力如下：始动、停止时 34.3N/mm² 以下，运转时 19.6N/mm² 以下

When design the connection tube, the system should be consider the vibration stress at the compressor start, stop and the system transportation status, ensure it doesn't be damaged. The recommendation value of the connection tube stress is below 34.3N/mm² at the start, stop status and below 19.6N/mm² at the running status.

2. 压缩机不允许横置、倒置，在搬运时不允许跌落。

Do Not Put a Compressor On Its Side OR Turn It Over. And Do Not Fall It Off When Moving.

3. 绝对不允许空气中运转

COMPRESSING AIR IS NOT PERMITTED.

4. 压缩机密封塞拔除后，请尽快使用，不要将压缩机长时间放置。

Please Assemble the Compressor in Your Air Conditioner Rapidly after Removing the Plugs. Don't Place the Comp. In Air for a long time.

5. 电气品要使用弊社所指定的规格同等品。

Please Use the Accessories Indicated By Our Company.

6. 冷媒量超过规定量时，需另行协商决定压缩机规格。（此时要考虑增加储液器、油加热器）

When the Amount of Refrigerant Charged in the Air Conditioner is Over the Max Amount Allowable, Compressor Specification Should Be Discussed. (Install

Additional Accumulator, Oil Heater, etc.)

7. 冷媒填充原则上从高压侧开始实行。
Refrigerant Must Always Be Filled From The Higher Side Of The Refrigeration Cycle.
8. 避免因误配线发生逆转。(若发生逆转, 则压缩机不能再使用)
Avoiding Compressor Running in Reverse Caused by Connecting Electrical Wire Incorrectly. (Don't Reuse the Compressor after Running in Reverse.)
9. 当旋转指令信号与转子位置检出信号不相匹配时, 会导致压缩机停止运转, 请注意。
When the Rotation Indication Signal is not Matched with the Rotor Position Checking Signal, the Compressor May Stop Running.
10. 绝对禁止将交流电直接印加在压缩机端子上, 否则会导致转子退磁。
Warning! In Case AC Voltage is Impressed to Compressor, the Compressor Performance Will Be Lower Because of it's Rotor Magnetic Force Decreasing.
11. 如变频驱动电源的晶体管发生短路(特别是在高转速 60 rps 以上时), 会导致转子退磁, 请注意。
Warning! In Case a Drive Transistor is Shorted in a High-Rotation (Over 60 rps), the Compressor Performance Will Be Lower Because of its Rotor Magnetic Force Decreasing.
12. 请不要裸手触摸运行中或刚停机正处于高温的压缩机, 当心烫伤。
Do not touch the compressor with bare hands during operation or immediately after stoppage. The compressor is at a high temperature. There is the danger of burns.
13. 维修保养设备时必须配戴防护眼镜。由于焊枪温度过高, 拆卸配管时, 当心会有冷媒、油的溅出而导致烫伤或进入眼中。
Wear safety goggles when servicing the unit. When removing the tubes by heating it with a burner, there is the danger of burns or eye injury if the refrigerant and/or oil remaining in the tubes is emitted.
14. 在贵司产品的保修和使用说明中, 请体现如下信息:
警告:
 - 当重新充注冷媒时, 为确保冷媒类型的正确性, 必须在制造商或者制造商指定的维修点或者服务机构进行。
 - 禁止混合使用冷媒。Below warning must be written into maintenance and user manual of whole unit:
WARNING:
 - When recharge the refrigerant, the processing must be done by the manufacturer or manufacturer appointed repair shop or service agent because correct type of refrigerant must be ensured.
 - Prohibition of mixing the refrigerants.

R32 压缩机运行范围

(R32 Operation Limitation of Compressor)

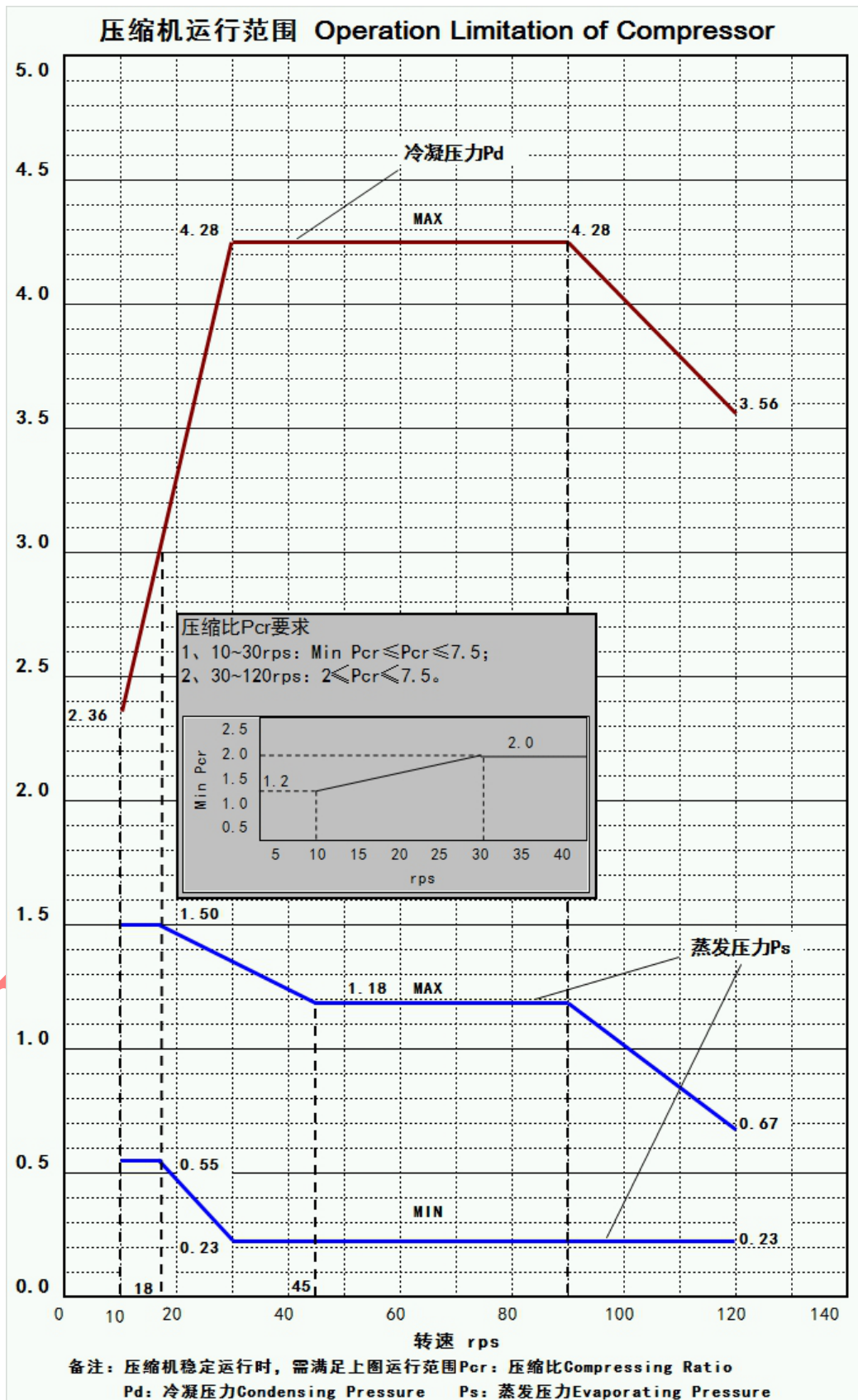

R410A 压缩机运行范围

(R410A Operation Limitation of Compressor)

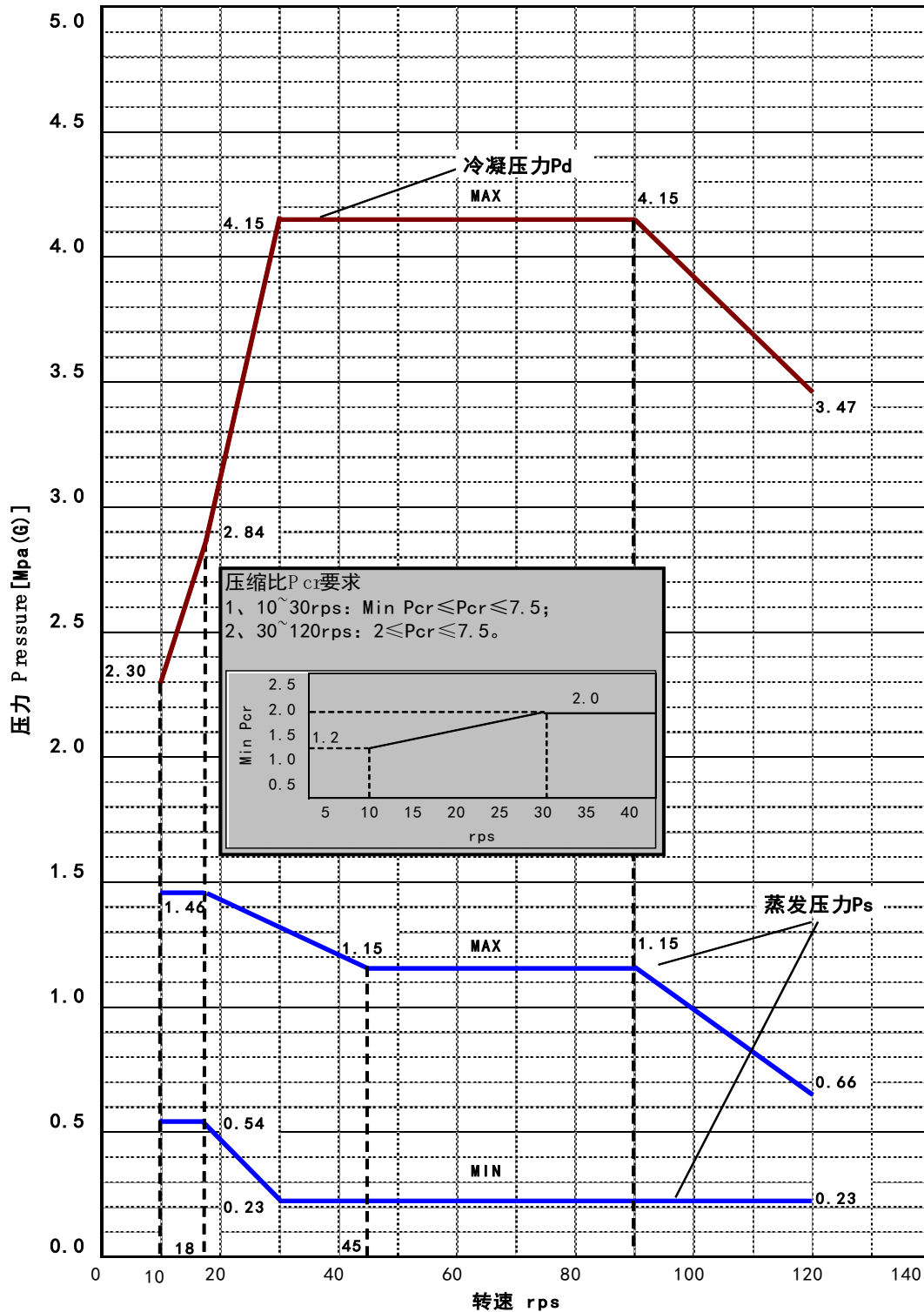

备注：压缩机稳定运行时，需满足上图运行范围；P_{cr}：压缩比Compressing Ratio
 Pd：冷凝压力Condensing Pressure Ps：蒸发压力Evaporating Pressure

图纸/附件清单 Drawing/Accessories List

(See the Attached Pages)

名称 Parts Name	数量 Pieces	图号 Drawing No.	备注 Remark
端子罩 TERMINAL COVER	1	MC71720310	
端子衬垫 TERMINAL PACKING	1	MC71720110	
端子螺母 TERMINAL NUT	1	MC33300810	
橡胶垫 RUBBER CUSHION	3	MC61910310	
压缩机外形图 COMPRESSOR DRAWING	1	MC51888310	
电机参数列表 MOTOR PARAMETER SHEET	1	-----	

电装品 ELE COMPONENTS

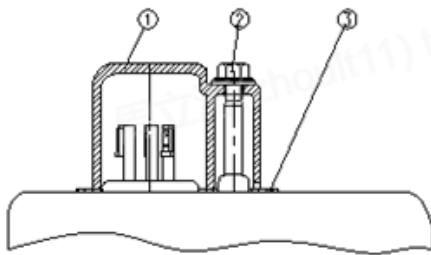
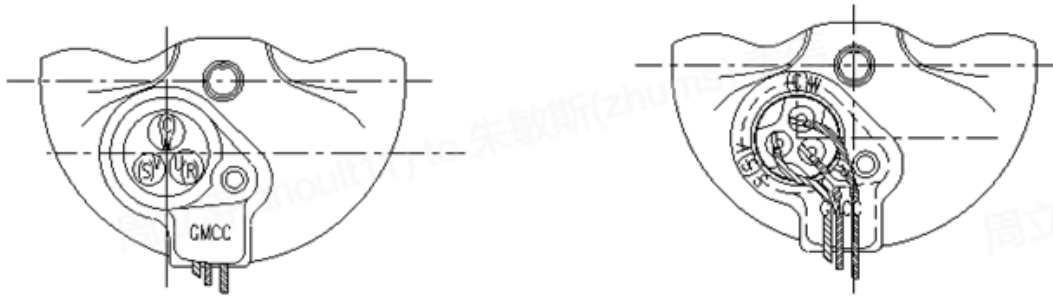

③	端子垫片 TERMINAL PACKING	MC71720110
②	端子螺母 TERMINAL NUT	MC33300810
①	端子盖 TERMINAL COVER	MC71720310
部件 Parts	部件名称 T I T L E	图号 Drawing No.

注释

NOTES

端子螺母的拧紧力矩: $1.2 \pm 0.2 \text{ N} \cdot \text{m}$

Tightening torque of TERMINAL NUT : $1.2 \pm 0.2 \text{ N} \cdot \text{m}$

端子盖 TERMINAL COVER

Drawing No. MC71720310

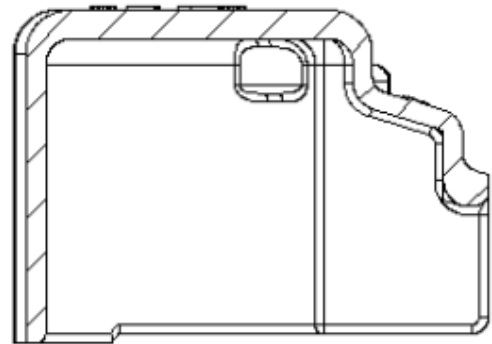
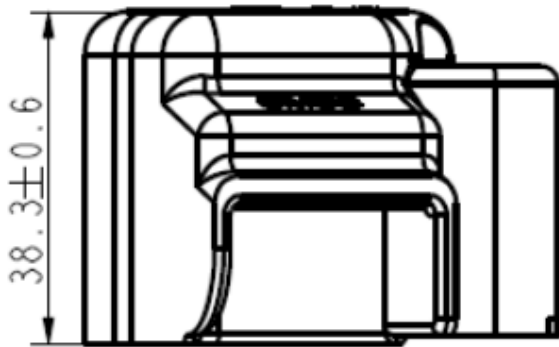
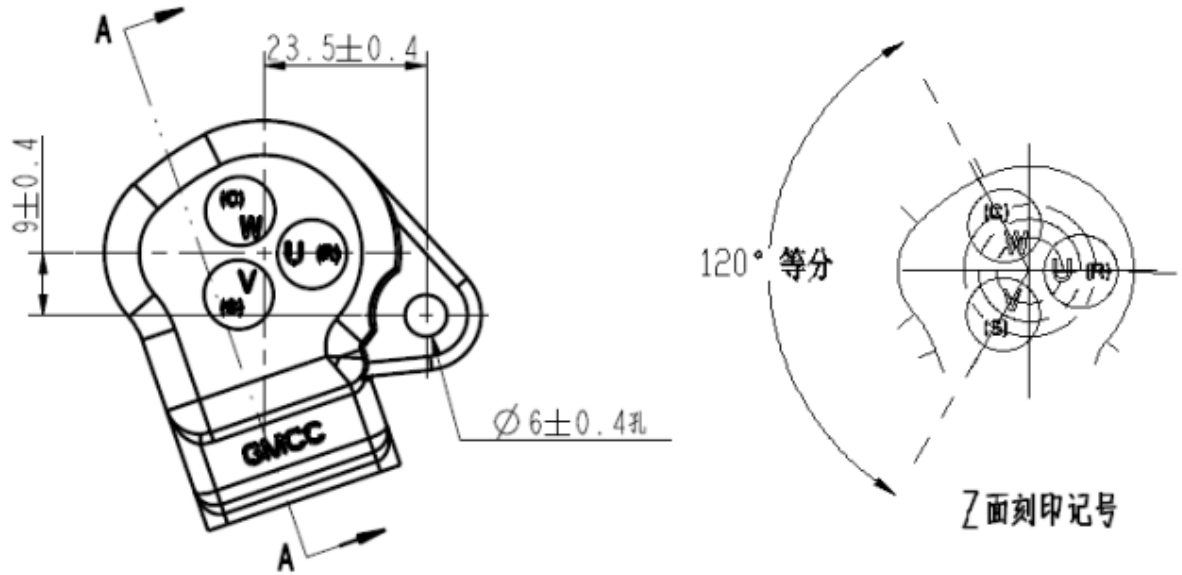

A-A 正向

注释
NOTES

材质: 聚对苯二甲酸丁二醇酯 或 团状模塑料 或 聚碳酸酯
MATERIAL: POLYBUTYLENE TEREPHTHALATE or BULK MOLDING COMPOUND or POLYCARBONATE

颜色: 黑色
COLOR: BLACK

端子垫片 TERMINAL PACKING

Drawing No.MC71720110

厚度 2.0 (+0.3, -0.1) mm
THICKNESS 2.0 (+0.3, -0.1) mm

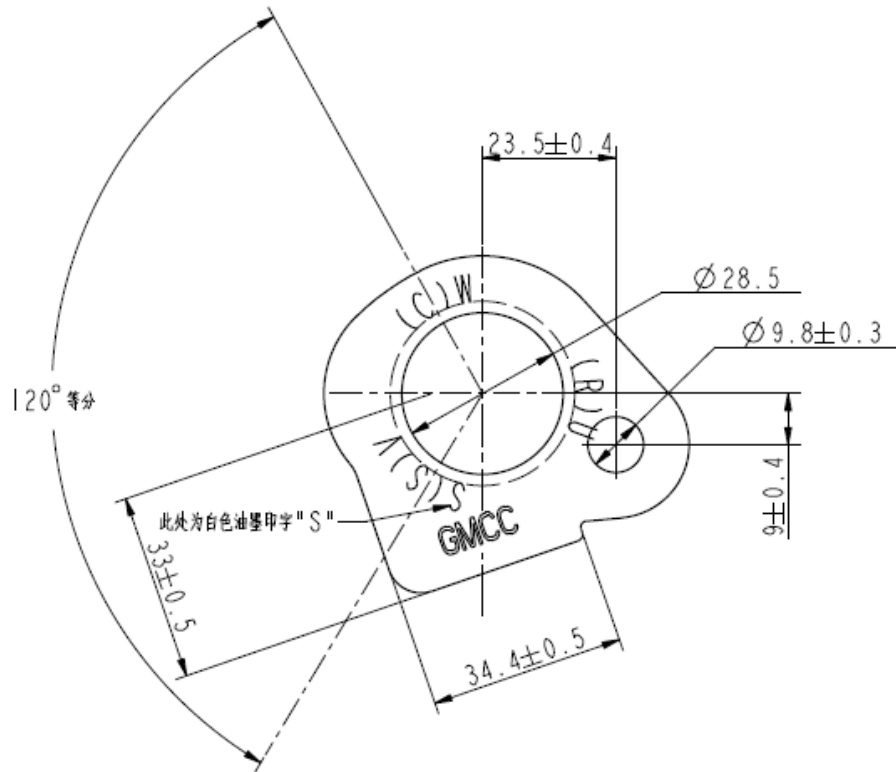

注释

NOTES

材质: 硅橡胶

MATERIAL:SI RUBBER

颜色: 黑色

COLOR:BLACK

端子螺母 TERMINAL NUT

Drawing No. MC33300810

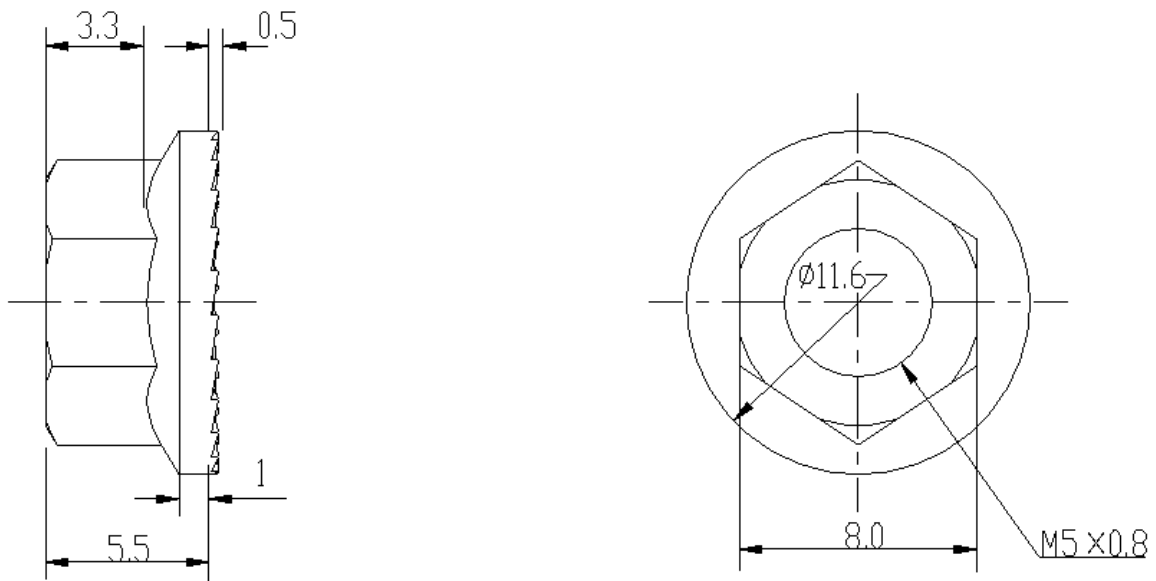

注释

NOTES

材质: SWCH12A

MATERIAL: SWCH12A

处理: 表面处理按Ep-Fe/Zn 2-CM 2镀锌处理

TREATMENT: WITHOUT HEXAVALENT CHROMIUM COMPOUNDS (Ep-Fe/Zn 2-CM 2镀锌处理)

橡胶垫 RUBBER CUSHION

Drawing:MC61910310

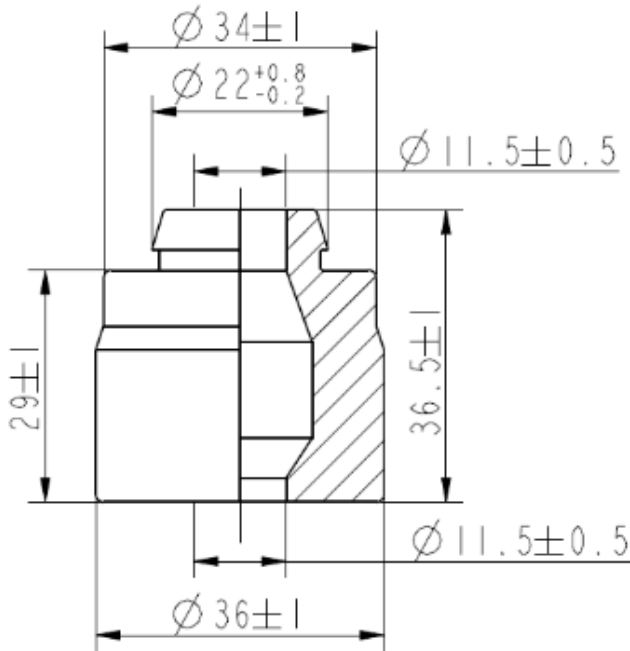

注释

NOTES

材质: 三元乙丙胶

MATERIAL: EPDM

硬度: HS=43±4

HARDNESS: HS=43±4

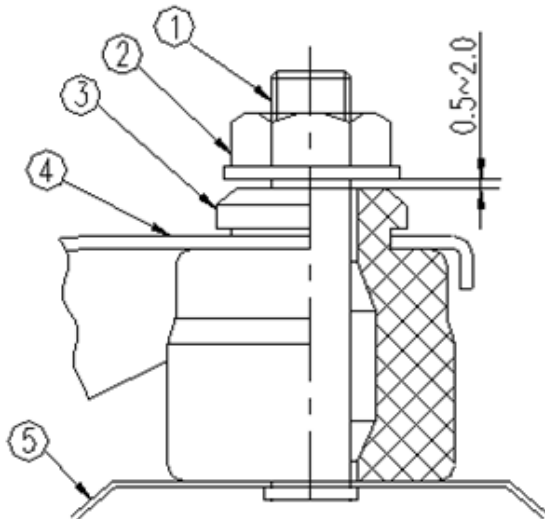

①	螺柱螺栓 STUD BOLT
②	螺母 NUT
③	橡胶垫 RUBBER CUSHION
④	压缩机底座 COMPRESSOR BASE
⑤	底板 BASE PLATE

安装组件

MOUNTING ASSEMBLY

外形图 (COMPRESSOR DRAWING)

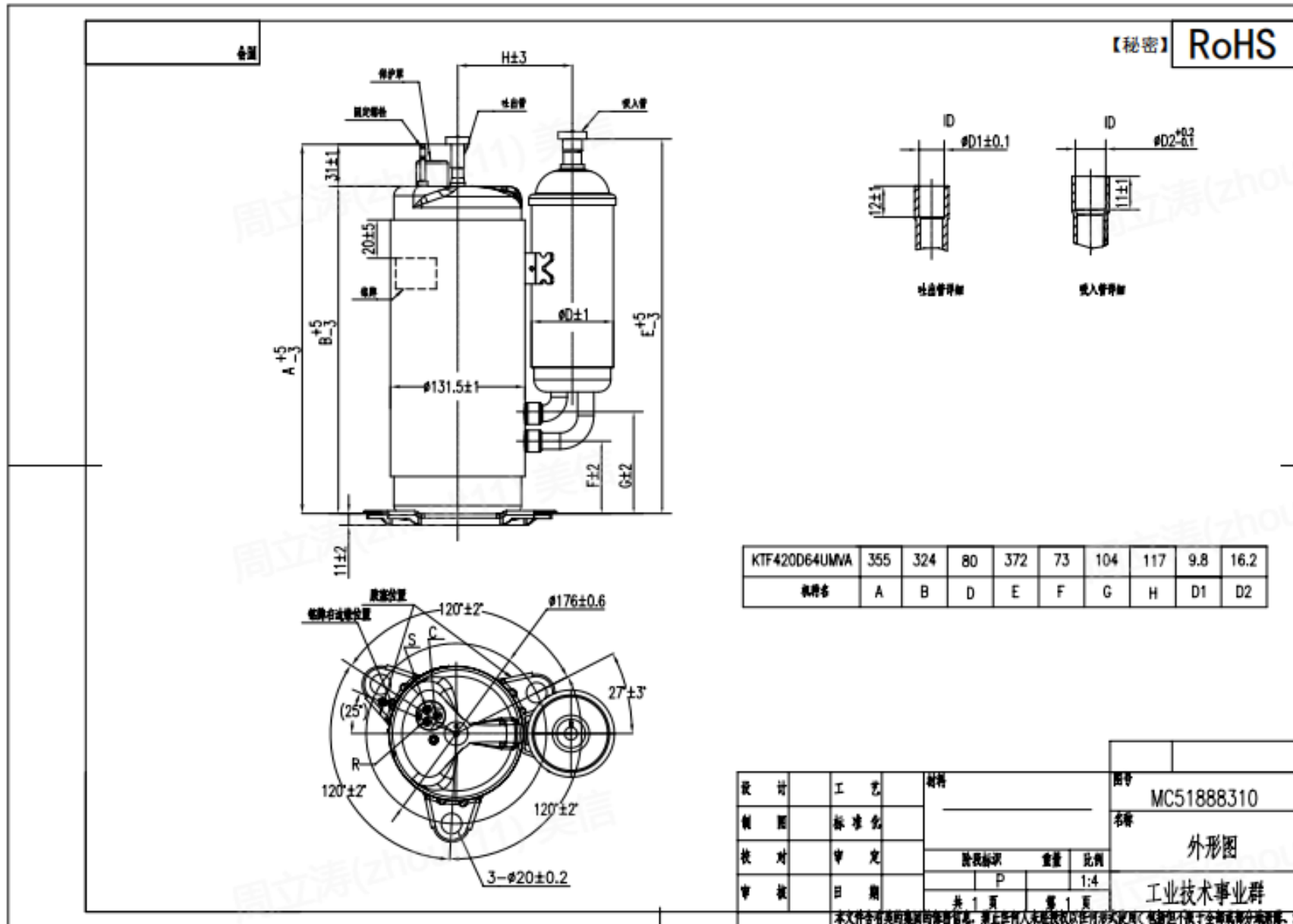

10、电机参数列表 (Motor Parameter Sheet)

No	项目 Item	参数 Parameter	备注 Remark
1	压缩机型号 Compressor Model	KTF420D64UMVA	
2	转子极数 Rotor Pole	6 极 Pole	
3	运行频率范围 Rated Frequency Range	12~120 rps	
4	磁石材料 Magnet Material	稀土 NdFeB	
5	永磁体减磁电流峰值 Demagnetizing Current	61A Apk	120°C下, -5%减磁率 at 120°C, -5% Demagnetizing Rate
6	d 轴电感 (相间) Inductance-Ld (per phase)	2.68 mH	额定电流下 Under Rated Current
7	q 轴电感 (相间) Inductance-Lq (per phase)	3.47 mH	额定电流下 Under Rated Current
8	定子线圈电阻 Winding Resistance	0.63 Ω	线间电阻 (20°C下) line-to-line (at 20°C)
9	感应电压常数 Voltage Constant	48.1 Vrms/Krpm	线间电压 line-to-line
10	电机转矩常数 Torque Constant	0.76 N·m/Arms	
11	转动惯量 Inertia	5.7x10 ⁻⁴ Kg·m ²	
12	磁通量 Φ _a Flux Φ _a	0.411~0.458 Wb·T	

11、电感及退磁曲线

