

Data sheet

Pressure operated water valve Types WVFX and WVS



Pressure operated water valves types WVFX and WVS are used for regulating the flow of water in refrigeration plants with water-cooled condensers.

The pressure operated water valves give modulating regulation of the condensing pressure within defined limits during operation. When the refrigeration plant is stopped, the cooling water flow is shut off automatically.

Pressure operated water valves can be used with flammable refrigerants. Double sealing between the refrigerant and the water line ensures that in case the bellows damage and the refrigerant leak, it cannot enter into the water. This severely limits the safety implications. It means that the valve can be used together with a double walled heat exchanger and water circuit in such a system does not need to be considered as a part of the installation for flammable refrigerants (EN378-1:2008, clause 4.4.2.2).

Features

- Media: Fresh water and Neutral brine
- Refrigerants: HCFC, HFC and HC
- Needs no power supply – self acting
- Opens on rising condensing pressure
- Complete flow range from 1.4 – 300 m³/h
- Low flow version of WVFX – 0,63 m³/h, (available on request)
- Insensitive to dirt
- WVFX 10 – 25 are available in stainless steel housing
- Suitable for flammable refrigerants
- Compliant with ATEX hazard zone 2

Technical data

Type	Condenser side				Liquid side			k _v value ¹⁾ [m ³ /h]
	Refrigerant	Control press. adjustable opening press. [bar]	Max. working pressure PS/MWP [bar]	Max. test pressure P _e [bar]	Media	Max. working pressure PS/MWP [bar]	Max. test pressure P _e [bar]	
WVFX 10	HCFC, HFC and HC	3.5 – 16.0	26.4	29.0	Fresh water, neutral brine, sea water ³⁾	16	24	1.4
WVFX 10 ²⁾		4.0 – 23.0	26.4	29.0		16	24	1.4
WVFX 10		15.0 – 29.0	45.2	60.0		16	24	1.4
WVFX 15		3.5 – 16.0	26.4	29.0		16	24	1.9
WVFX 15 ²⁾		4.0 – 23.0	26.4	29.0		16	24	1.9
WVFX 15		15.0 – 29.0	45.2	60.0		16	24	1.9
WVFX 20		3.5 – 16.0	26.4	29.0		16	24	3.4
WVFX 20 ²⁾		4.0 – 23.0	26.4	29.0		16	24	3.4
WVFX 20		15.0 – 29.0	45.2	60.0		16	24	3.4
WVFX 25		3.5 – 16.0	26.4	29.0		16	24	5.5
WVFX 25 ²⁾		4.0 – 23.0	26.4	29.0		16	24	5.5
WVFX 25		15.0 – 29.0	45.2	60.0		16	24	5.5
WVFX 32		4.0 – 17.0	24.1	26.5		10	10	11.0
WVFX 40		4.0 – 17.0	24.1	26.5		10	10	11.0
WVS 32	HCFC, HFC, HC, R717	2.2 – 19.0	26.4	29.0	Fresh water, neutral brine	10	16	12.5
WVS 32		15.0 – 29.0	45.2	60.0		10	16	12.5
WVS 40		2.2 – 19.0	26.4	29.0		10	16	21.0
WVS 40		15.0 – 29.0	45.2	60.0		10	16	21.0
WVS 50		2.2 – 19.0	26.4	29.0		10	16	32.0
WVS 50		15.0 – 29.0	45.2	60.0		10	16	32.0
WVS 65		2.2 – 19.0	26.4	29.0		10	16	45.0
WVS 65		15.0 – 29.0	45.2	60.0		10	16	45.0
WVS 80		2.2 – 19.0	26.4	29.0		10	16	80.0
WVS 80		15.0 – 29.0	45.2	60.0		10	16	80.0
WVS 100		2.2 – 19.0	26.4	29.0		10	16	125.0
WVS 100		15.0 – 29.0	45.2	60.0		10	16	125.0

¹⁾ The k_v value is the flow of water in [m³/h] at a pressure drop across valve of 1 bar, ρ = 1000 kg/m³.

²⁾ Fully open valve requires 33% higher pressure than a WVFX, range 3.5 – 16 bar.

³⁾ WVFX 15, WVFX 20 and WVFX 25 with stainless steel housing only.

WVFX 10 – 40 are direct actuated valves.
WVFX 32 – 100 are servo-operated valves.

Media temperature range

WVFX 10 – 25: -25 – 130 °C
WVFX 32 – 40: -25 – 90 °C
WVS: -25 – 90 °C

If a WVS is required with an opening differential pressure of 1 – 10 bar, the valve servo spring must be replaced. See "Ordering".

Opening differential pressure

WVFX 10 – 25: max. 10 bar
WVFX 32 – 40: max. 10 bar
WVS 32 – 40: min. 0.5 bar; max. 4 bar
WVS 50 – 100: min. 0.3 bar; max. 4 bar

Below 20% of max. capacity the WVS will act as an on-off regulator.

Ordering

WVFX, commercial type

Type	Connection ¹⁾		Range [bar]	Code no.
	Water side	Condenser side		
WVFX 10	G 3/8	1/4 in. / 6 mm flare	3.5 – 16	003N1100
WVFX 10	G 3/8	1 1/4 in. / 6 mm flare	4.0 – 23	003N1105
WVFX 15	G 1/2	1/4 in. / 6 mm flare	3.5 – 16	003N2100
WVFX 15	G 1/2	1/4 in. / 6 mm flare	4.0 – 23	003N2105
WVFX 15	G 1/2	1/4 in. / 6 mm flare nut	4.0 – 23	003N2205 ²⁾
WVFX 20	G 3/4	1/4 in. / 6 mm flare	3.5 – 16	003N3100
WVFX 20	G 3/4	1/4 in. / 6 mm flare	4.0 – 23	003N3105
WVFX 20	G 3/4	1/4 in. / 6 mm flare nut	4.0 – 23	003N3205 ²⁾
WVFX 25	G 1	1/4 in. / 6 mm flare	3.5 – 16	003N4100
WVFX 25	G 1	1/4 in. / 6 mm flare	4.0 – 23	003N4105
WVFX 32	G 1 1/4	1/4 in. / 6 mm flare	4.0 – 17	003F1232
WVFX 40	G 1 1/2	1/4 in. / 6 mm flare	4.0 – 17	003F1240

¹⁾ ISO 228-1

²⁾ WVFX 15 with 1 m capillary tube and flare nut with valve depressor

WVFX, maritime type (stainless steel version)

Type	Connection ¹⁾		Range [bar]	Code no.
	Water side	Condenser side		
WVFX 15	G 1/2	1/4 in. / 6 mm flare	3.5 – 16	003N2101
WVFX 15	G 1/2	1/4 in. / 6 mm flare	4.0 – 23	003N2104
WVFX 20	G 3/4	1/4 in. / 6 mm flare	4.0 – 23	003N3104
WVFX 25	G 1	1/4 in. / 6 mm flare	3.5 – 16	003N4101
WVFX 25	G 1	1/4 in. / 6 mm flare	4.0 – 23	003N4104

¹⁾ ISO 228-1

WVFX, commercial type (high pressure refrigerants, MWP 45.2 bar)

Type	Connection ¹⁾		Range [bar]	Code no.
	Water side	Condenser side		
WVFX 10	G 3/8	1/4 in. / 6 mm flare	15.0 – 29.0	003N1410
WVFX 15	G 1/2	1/4 in. / 6 mm flare	15.0 – 29.0	003N2410
WVFX 20	G 3/4	1/4 in. / 6 mm flare	15.0 – 29.0	003N3410
WVFX 25	G 1	1/4 in. / 6 mm flare	15.0 – 29.0	003N4410

¹⁾ ISO 228-1

Ordering
(continued)

WVS, commercial type

Type	Connection ¹⁾	Code no.				
		Valve body	Pilot unit ³⁾	Pilot unit for R410A and R744 ³⁾	Flange set ⁴⁾	Servo spring for differential pressure range of 1 – 10 bar
WVS 32	G 1 ¼ ¹⁾	016D5032	016D1017	016D1018	—	016D1327
WVS 40	G 1 ½ ¹⁾	016D5040	016D1017	016D1018	—	016D0575
WVS 50	2 in. weld flange	016D5050 ²⁾	016D1017	016D1018	027N3050	016D0576
WVS 65	2 ½ in. weld flange	016D5065 ²⁾	016D1017	016D1018	027N3065	016D0577
WVS 80	3 in. weld flange	016D5080 ²⁾	016D1017	016D1018	027N3080	016D0578
WVS 100	4 in. weld flange	016D5100 ²⁾	016D1017	016D1018	027N3100	016D0579

¹⁾ ISO 228-1

³⁾ Parts included: control element and spring housing.

²⁾ Parts included: valve body, flange gaskets, flange bolts and screws for pilot valve.

⁴⁾ Parts included: 2 flanges

Accessories

Description	Code no.
1 m capillary tube ¼ in. (6 mm) flare coupling nuts at each end	060-017166
Bracket for WVFX 10 – 25	003N0388

Capacity

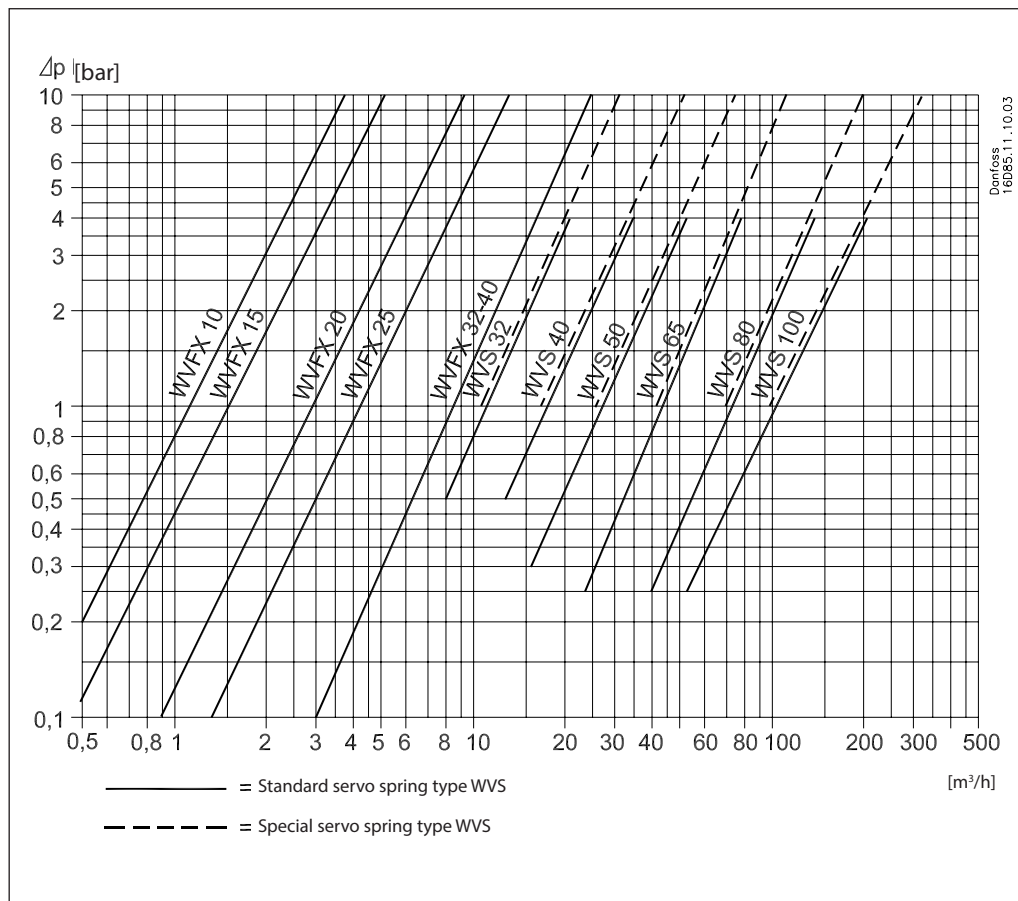

Water Valves Offset – rise in condensing pressure

Type	[bar] Δp
WVFX 10	2.0
WVFX 15	2.5
WVFX 20	3.0
WVFX 25	3.5
WVFX 32 – 40	3.0
WVS 32	0.6
WVS 40	0.7
WVS 50 – 80	0.8
WVS 100	0.9

The capacity curves show the capacities of individual valves (water quantity in [m³/h]) depending on the pressure drop across valves.

The capacities given apply at 85% valve opening and are obtained with the following offset (rise in condensing pressure).

Design / Function

Condensing pressure impulses are transmitted via the bellows element to the valve cone so that the valve – even at very small pressure variations – is able to adapt the quantity of water required by the condenser.

The valves are pressure-relieved in such a way that a variation in the water pressure will not affect their setting.

To protect the refrigeration plant against high head pressures in the event that the water supply to the condenser fails, a safety switch type KP or RT should be fitted on the high pressure side.

Water side connections are internal BSP and the compressor discharge side connection is ¼ in. / 6 mm flare.

The valve body WVFX 10 – 25 is made of hot-stamped brass and for WVFX 32 – 40 of cast iron. WVFX 15, WVFX 20 and WVFX 25 can also be supplied in stainless steel housing.

All metal external valve parts are surface-treated to resist corrosion from condensate, etc.

It is possible to order reverse acting WVFX valve, which opens on refrigerant pressure decrease.

Reverse acting valve are mostly used in bypass lines and heat pump applications.

WVFX 10 – 25

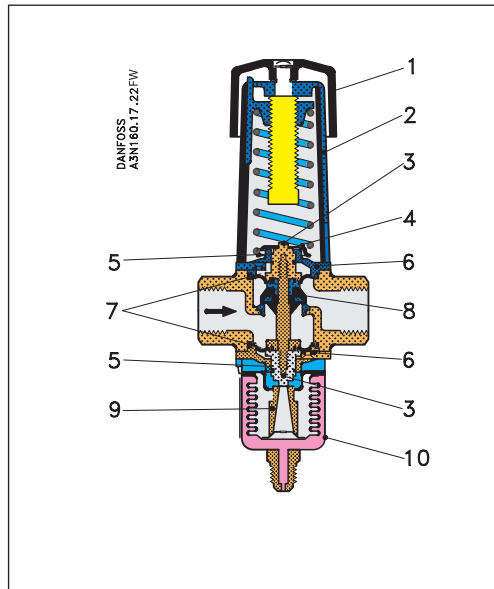

1. Handwheel
2. Spring housing
3. Spindle guide
4. Spring retainer
5. O-ring
6. Guide bush
7. Diaphragm
8. Valve cone
9. Thrust pad
10. Bellows element

The valve cone (8) is a brass plate with a vulcanized layer of artificial rubber to form an elastic seal against the valve seat. The valve is externally sealed by the diaphragms (7).

The top and bottom of the valve plate holder are extended by a guide that is fitted with O-rings (5) to ensure the internal operating parts move correctly. These O-rings, fitted in conjunction with the diaphragms, also provide extra protection against external leakage.

The valve seat is made of stainless steel and is pressed to the valve body.

The spring housing (2) is of aluminium and has a guide slot for the spring holder that is extended in the form of an indicating pointer. An associated indicator label is riveted to the housing and is graduated from 1 – 5.

WVFX 32 – 40

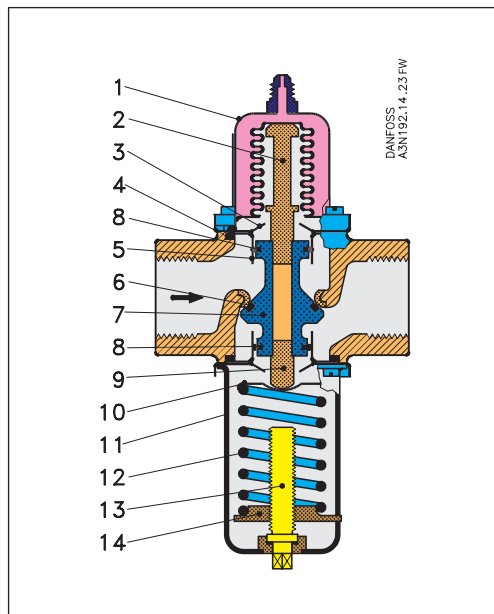

1. Bellows element
2. Upper pressure spindle
3. Top plate
4. Guide bush gland
5. Guide bush
6. T-ring
7. Valve cone
8. O-ring
9. Lower pressure spindle
10. Spring retainer
11. Spring housing
12. Regulating spring
13. Regulating spindle
14. Spring holder

The valve cone (7) is made of brass with a T-ring (6) of artificial rubber forming a flexible seal against the valve seat. The O-rings (8) are external seals for the cooling water.

The valve cone guide bushes (5) are specially treated to counteract lime deposits from the cooling water inside the cylinder, and also to reduce friction in the valve to a minimum.

The valve seat is made of stainless steel and is pressed to the valve body.

The regulating spindle (13) is mounted in a guide in the spring housing which has a notch for the spring holder (14). The spring holder also acts as an indicator.

Design / Function
(continued)

WVS 32

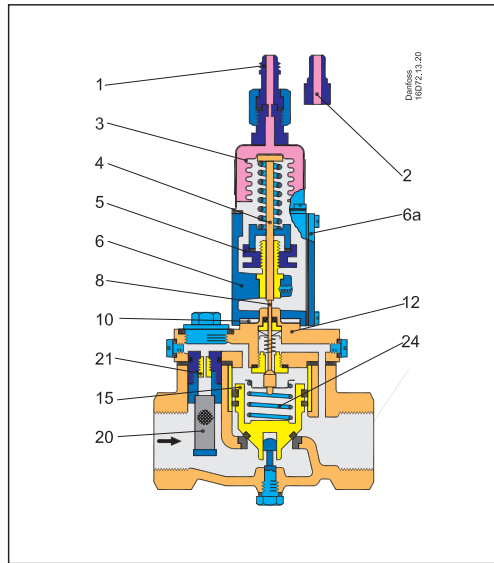

WVS 40

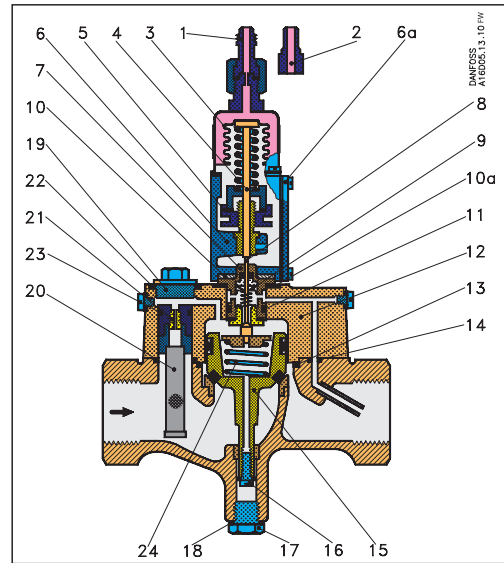

1. Pressure connection (flare nipple)
2. Pressure connection (weld nipple)
3. Bellows element
4. Push rod
5. Regulating nut
6. Spring housing
- 6a. Cover
7. Pilot assembly
8. Spindle for pilot cone
9. Teflon sleeves
10. Insulating gasket
- 10a. Gasket
11. O-ring
12. Valve cover
13. O-ring
14. O-ring
15. Servo piston
16. Bottom screw
17. Drain plug
18. Gasket
19. Strainer assembly, complete
20. Self-cleaning strainer assembly
21. Pilot orifice
22. Gasket
23. O-ring
24. Servo spring

WVS 50 – 100

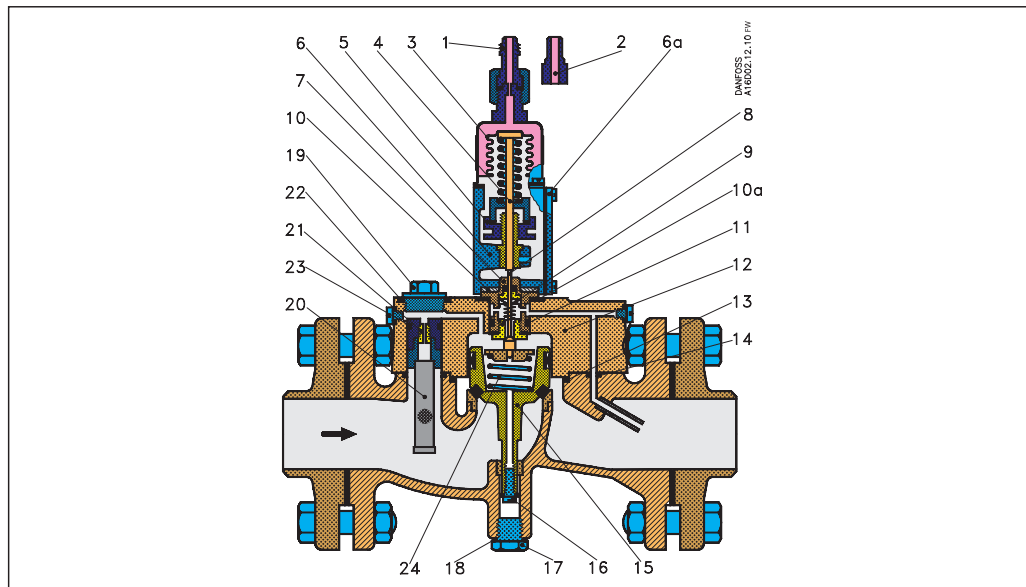

WVS 32 – 40 valves have internal BSP connections, while WVS 50 – 100 can be supplied with either BSP connections or weld flanges.

Connection to the plant condenser can be made by copper tube or steel tube, the valves being supplied with both a flare nipple for 1/4 in. (6 mm) copper tube and a weld nipple for ø6 mm / ø10 mm steel tube.

The valve consists of three main components:

1. Main valve with servo piston

The main valve body is made of cast iron with a pressed-in bronze seat. The servo piston is of gun metal and has a sleeve and a profiled rubber seal ring.

2. Pilot valve

The pilot valve is made of gun metal, the pilot cone and seat of stainless steel and the pilot orifice of brass. These materials are particularly resistant to water corrosion. However, the valve is not resistant to sea water.

The strainer ahead of the pilot orifice is made of nickel gauze.

The degree of opening of the pilot valve (which corresponds to the increase in condensing pressure above the set opening pressure) determines the degree of opening of the main valve and thereby amount of the water flow.

3. Bellows unit with connection to condenser

The bellows unit is made of aluminium and corrosion-protected steel.

Sizing

When sizing and selecting water regulating valves it is most important to ensure that the valve at any time is able to give the necessary quantity of cooling water.

In general, the aim should be to select the smallest valve capable of giving the required flow.

To select a suitable size of valve it is necessary to know the precise amount of cooling required.

To obtain a precise control it can be recommended to only use 85% of the capacity. Below 85% the ratio between flow and condensing difference pressure is linear. Above 85% the ratio is no longer linear. To reach a 100% capacity the water valve needs significant increase of condensing pressure. See fig. below.

On the other hand, to avoid the risk of unstable regulation (hunting) the valve should not be oversized.

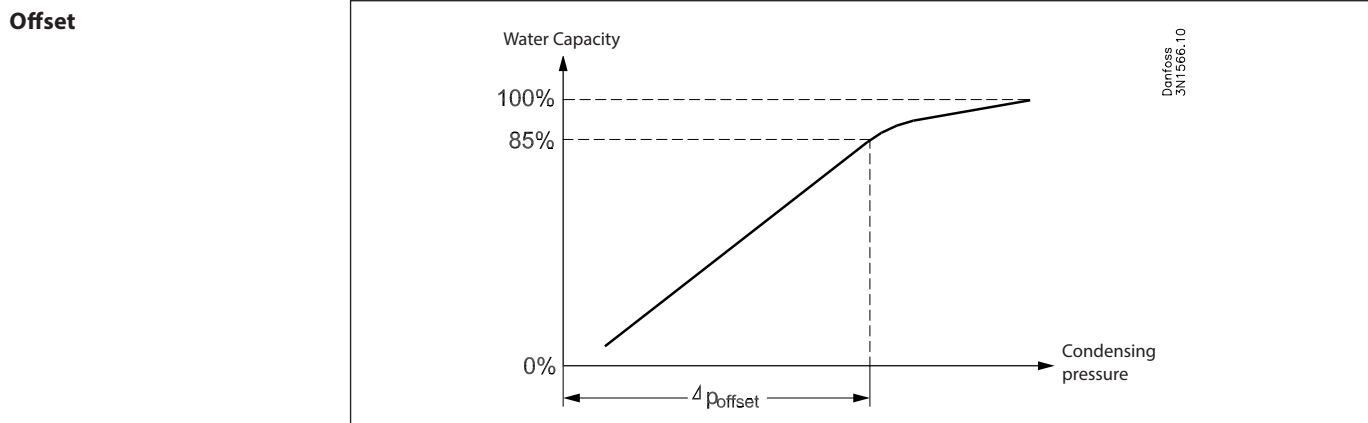

Type	Δp offset [bar]
WVFX 10	2.0
WVFX 15	2.5
WVFX 20	3.0
WVFX 25	3.5
WVFX 32 – 40	3.0
WVS 32	0.6
WVS 40	0.7
WVS 50 – 80	0.8
WVS 100	0.9

Valve size

The following data is used when selecting the size of the water valve:

- Cooling capacity of condenser
- Temperature rise in cooling media
- Differential pressure across valve
- Condensing temperature
- Specific heat capacity of cooling media
- Refrigerant

Sizing Examples

Example 1:
 Condenser capacity Q_c : 30 kW
 Condensing temperature t_0 : 35 °C
 Refrigerant: R404A
 Cooling media: water

Specific heat capacity of water C_p : 4.19 kJ/(kg*K)
 Water inlet temperature t_1 : 15 °C
 Water outlet temperature t_2 : 25 °C
 Pressure drop across valve Δ_p : max. 1.0 bar

Necessary mass flow	$\dot{m} = \frac{Q_c}{C_p \cdot (t_2 - t_1)} \cdot 3600 = \frac{30}{4.19 \cdot (25 - 15)} \cdot 3600 = 2577 \text{ kg/h}$
Volume flow	$\dot{V} = \frac{\dot{m}}{\rho} = \frac{2577}{1000} \approx 2.6 \text{ m}^3/\text{h}$

Selecting size

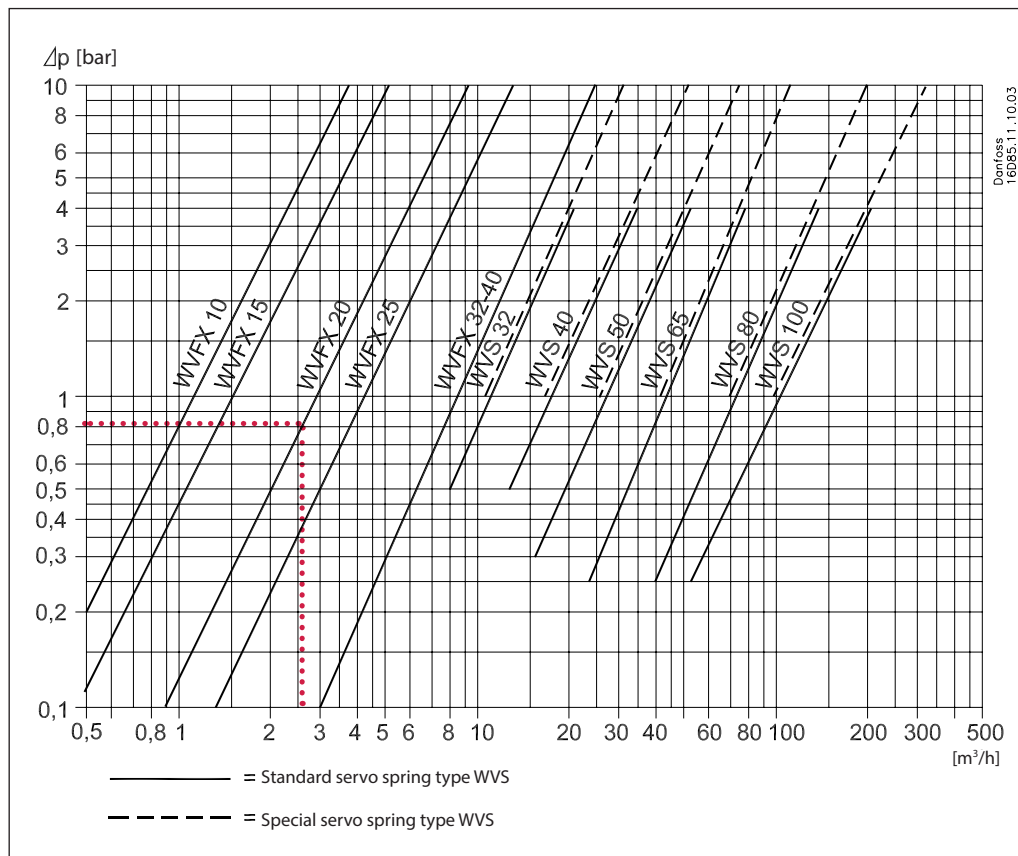

Selecting WVFX 20

Code number
The saturated pressure for R404A
 $T_c = 35\text{ °C} \Rightarrow P_c = 15.5\text{ barg}$

Choose a WVFX 20 with 4 – 23 barg range

Example 2:

Condenser capacity Q_c : 20 kW
Condensing temperature t_c : 35 °C
Refrigerant: R134a
Cooling media: Brine
Density of brine ρ : 1015 kg/m³

Specific heat capacity of water C_p : 4.35 kJ/(kg*K)
Water inlet temperature t_1 : 20 °C
Water outlet temperature t_2 : 25 °C
Pressure drop across valve Δp : max. 2.0 bar

Necessary mass flow	$\dot{m} = \frac{Q_c}{C_p \cdot (t_2 - t_1)} \cdot 3600 = \frac{20}{4.35 \cdot (25 - 20)} \cdot 3600 = 3310\text{ kg/h}$
Volume flow	$\dot{V} = \frac{\dot{m}}{\rho} = \frac{3310}{1015} \approx 3.26\text{ m}^3/\text{h}$
k_v value	$k_v \geq \frac{\dot{V}}{\sqrt{\frac{1000 \cdot \Delta p}{\rho}}} = \frac{3.26}{\sqrt{\frac{1000 \cdot 2.0}{1015}}} = 2.32\text{ m}^3/\text{h}$

Selecting size of WVFX 20

$k_v \geq 2.32\text{ m}^3/\text{h} \Rightarrow$ **WVFX 20**
WVFX 20 has $k_v = 3.4\text{ m}^3/\text{h}$ and the necessary capacity is below 85% of full capacity

Code number
The saturated pressure for R134a
 $T_c = 35\text{ °C} \Rightarrow P_c = 7.9\text{ barg}$

Choose a WVFX 20 with 3.5 – 16 barg range

Dimensions [mm]
and weights [kg]

WVFX 10 – 25

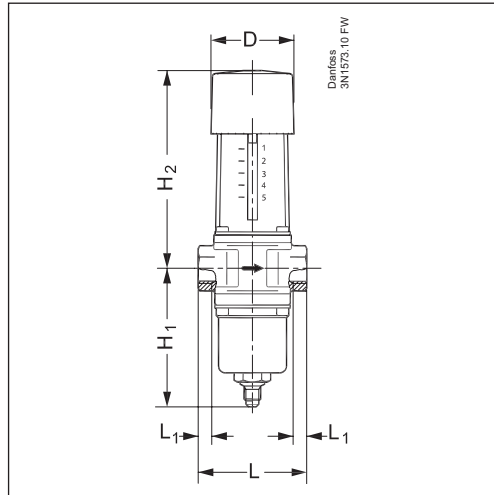

Bracket for WVFX 10 – 25

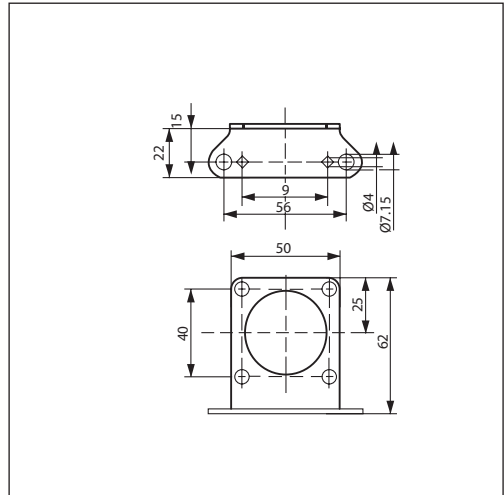

WVFX 32 – 40

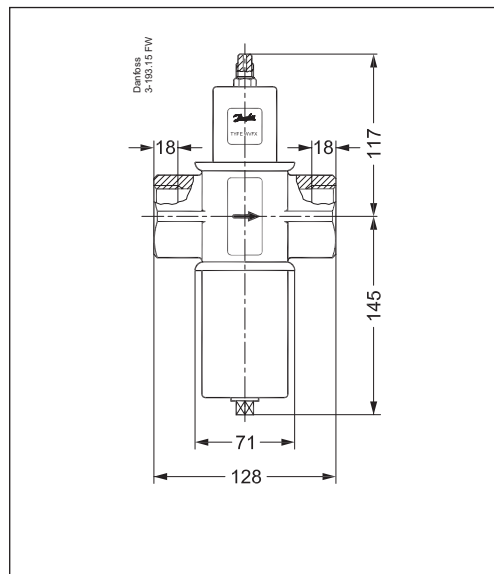

WVS 32 – 40

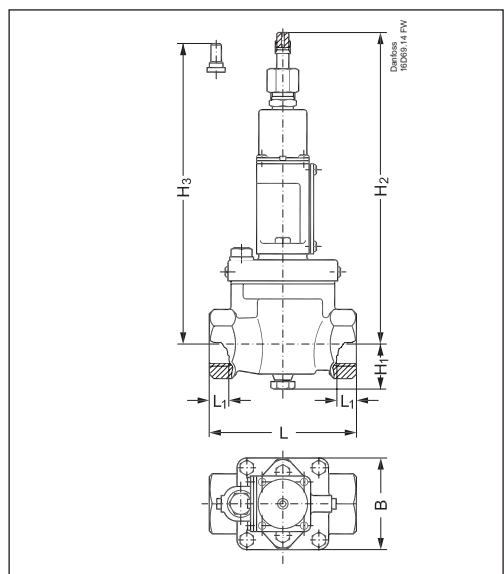

WVS 50 – 100

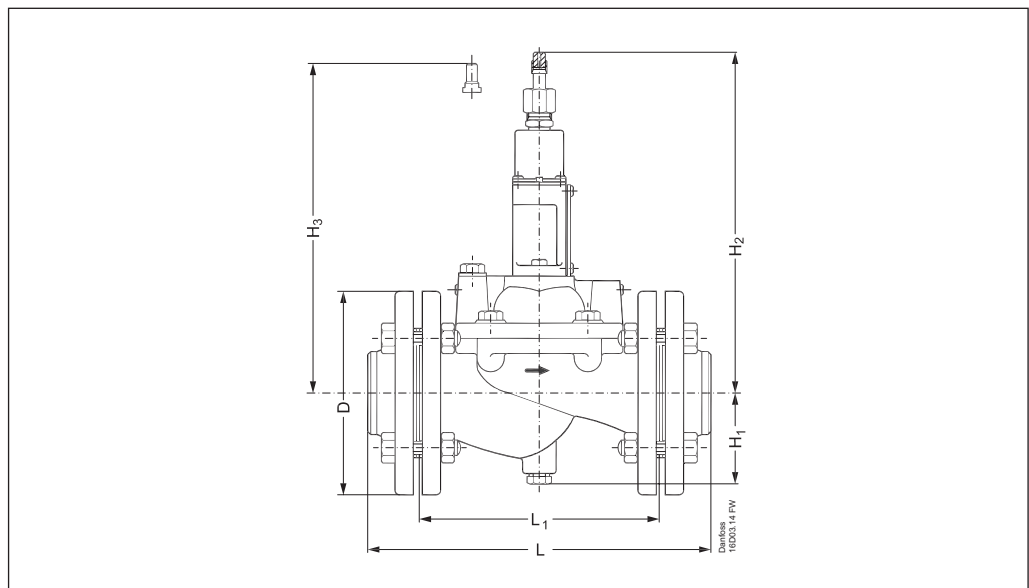

**Dimensions [mm]
and weights [kg]**
(continued)

Pressure operated water valve

Type	H ₁	H ₂	H ₃	L	L ₁	B	∅	Net weight
WVFX 10	91	133	—	72	11	—	55	1.0
WVFX 15	91	133	—	72	14	—	55	1.0
WVFX 20	91	133	—	90	16	—	55	2.0
WVFX 25	96	138	—	95	19	—	55	2.0
WVS 32	42	243	234	138	20	85	—	4.0
WVS 40	72	271	262	198	30	100	—	7.0
WVS 50	78	277	268	315	218	—	165	19.0
WVS 65	82	293	284	320	224	—	185	24.0
WVS 80	90	325	316	370	265	—	200	34.0
WVS 100	100	345	336	430	315	—	220	44.0

Pressure operated water valve, type WVS - high pressure refrigerants

Type	H ₁	H ₂	H ₃	L	L ₁	B	∅	Net weight
WVS 32	42	259	250	138	20	85	—	4.0
WVS 40	72	287	278	198	30	100	—	7.0
WVS 50	78	293	2684	315	218	—	165	19.0
WVS 65	82	309	300	320	224	—	185	24.0
WVS 80	90	341	332	370	265	—	200	34.0
WVS 100	100	361	352	430	315	—	220	44.0