

VISTA di "Riferimento"

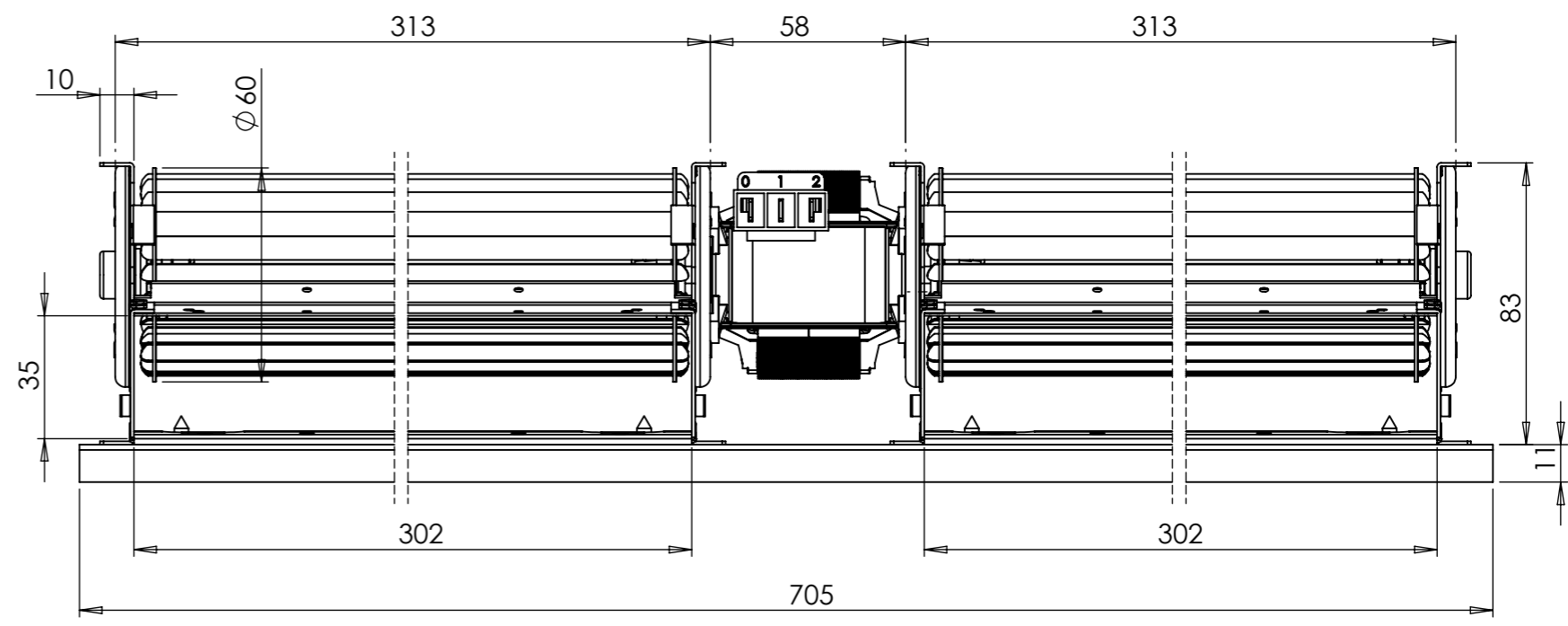
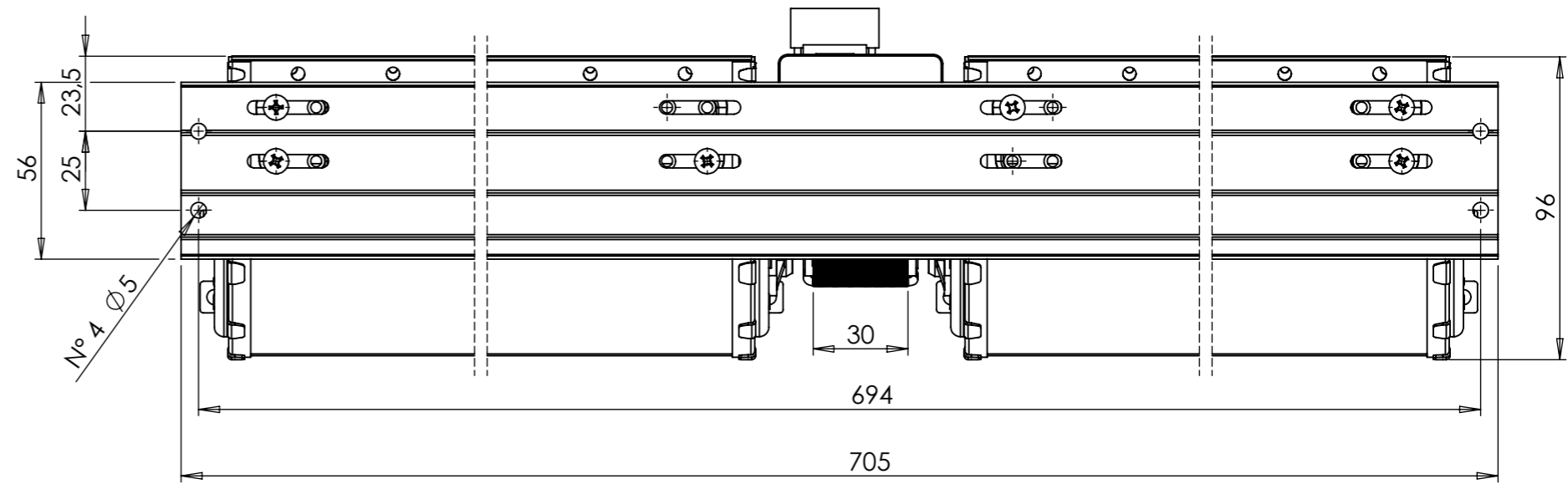
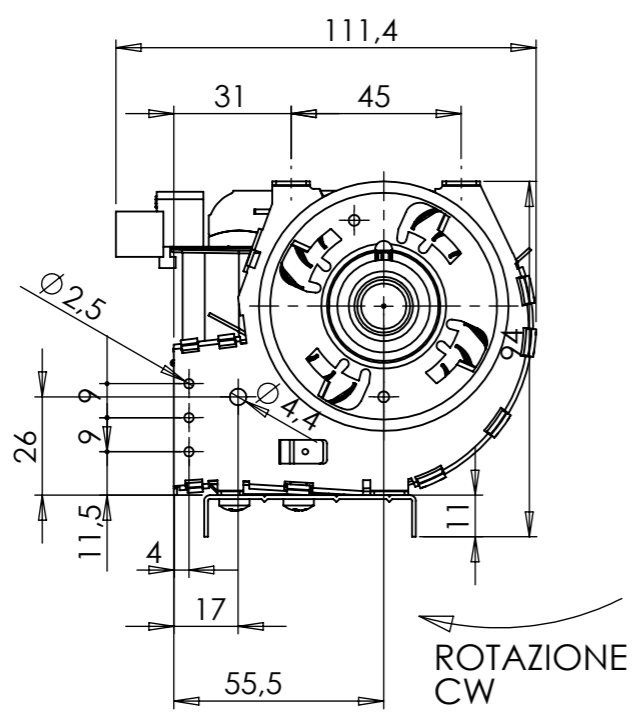

PER APPROVAZIONE

FIRMA \_\_\_\_\_

DATI CARATTERISTICI A 50HZ/TECHNICAL DATA AT 50HZ			Mod.
"TAD30B-006-00"			
Tensione nominale/Rated Voltage	V	230	
Frequenza/Rated Frequency	Hz	50-60	
Potenza assorbita/Input Power	W	40	
Classe isolamento/Insulation class (IEC 60085)		F	
Max temp./Max ambient temperature(IEC 60335-1)	°C	60	
N° di giri a vuoto/Rated speed no load	Rpm	950	
Portata a bocca libera/Rated airflow	m³/h	330	
Pressione statica/Static pressure	Pa	44	
Rotazione/Rotation (side View)		CW	
Funzionamento continuativo/Continuous duty			

Materiale:	Peso netto [g]:	Trattamento:
<b>TRIAL Srl</b> S.Giuliano M.se Via dei Mille, 3 Tel (0039) 029822231 Uff. Commerciale Tel (0039) 029822351 Uff. Tecnico Fax (0039) 0298243291	Per le quote lineari ed angolari prive di tolleranza, riferirsi alla norma UNI ISO 2768 grado Medio.	Dis. : Rizzi M. Data : 05/05/15 Scala : 1:2 Visto : -
Descrizione: TFA005-R5-	230V50/60HZ	Foglio 1 / 1
		Codice <b>TAD30B-006</b>
		Mod. <b>00</b>