

FLOAT
M015.000007

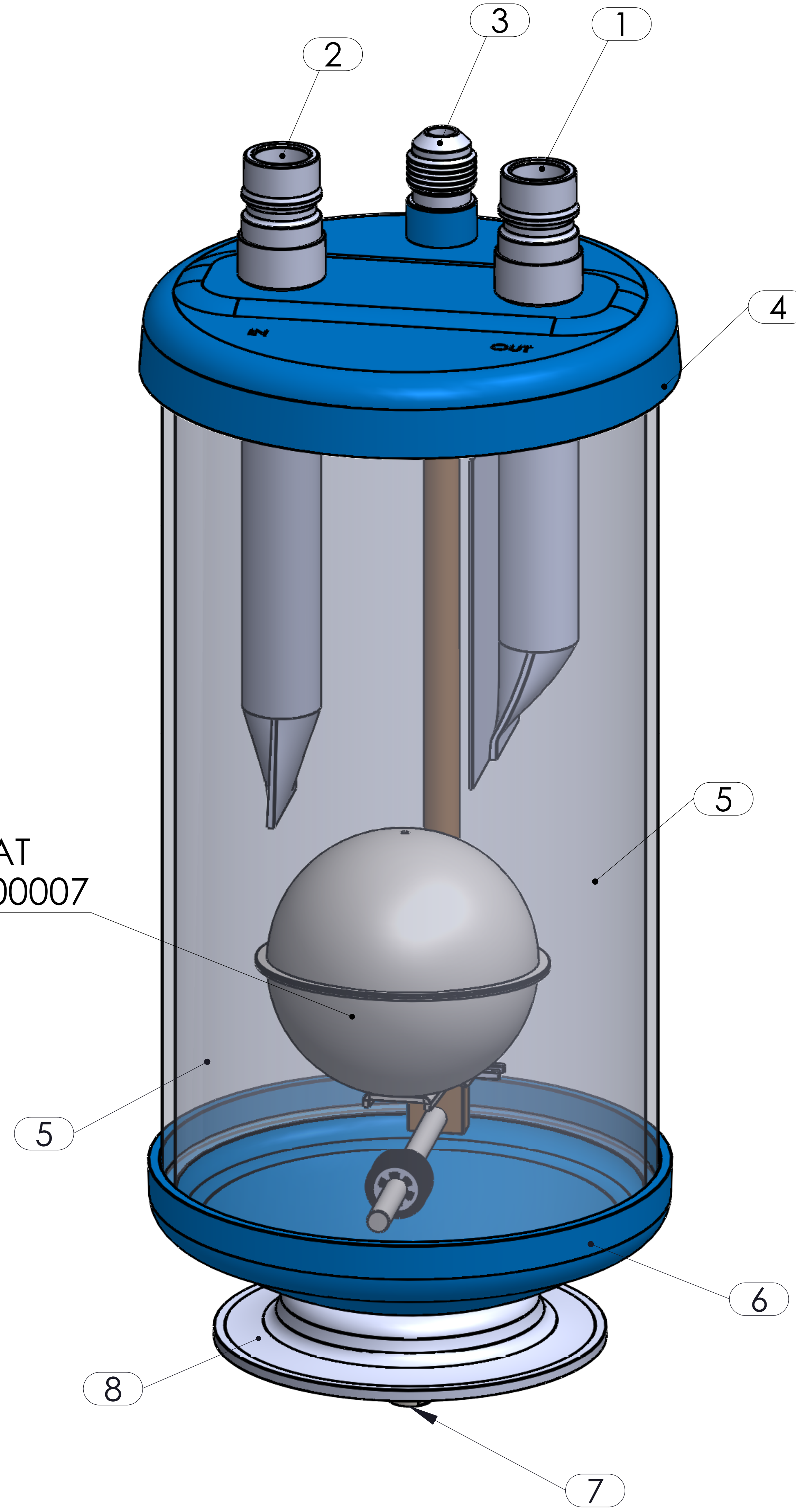

GÜVEN SOĞUTMA ÜNİTELERİ SAN. VE TİC. A.Ş.

Addr.: Hastane Mah. Hadimköy İstanbul Cd. No:78/1
34555, Arnavutköy, İstanbul, TÜRKİYE
Tel: +90 212 771 51 12 - 771 51 13
Fax: +90 212 771 51 10
www.gvn.com.tr



GVN STANDART PRODUCT

Customer

CONVENTIONAL OIL SEPARATORS

Product

OS.30b.12.1

Code

Customer Code

DESIGN DATA

Capacity [Lt.]	0,6 Lt. / 2,1 Lt.
Design Pressure [PS]	30 Bar
Pneumatic Test Pressure [PT]	33 Bar
Hydraulic Test Pressure	43 Bar
Design Temperature [TS]	Min.-20C / Max.+130C
Cooler Fluid Type	HFC-CFC-HCFC
Fluid Group	2
Category	CAT I / A
Design Calculation	EN 14276-1/EN 13445-3
Welded Joint Efficiency	0.85
Material Group (Shell / Head)	1.2
Testing Group	3b
Corrosion Allowance	0,5 mm
Ndt	10%
Packaging Size & Weight	00*00*00 & 00 Kg.
Drawn By	Ö.TÜRKER
Approved By	D.GÜL
Date	04.03.2022
Color	RAL 5009

MATERIAL DATA

No	Connection	Model	Code	Material	Qty
1	Inlet Connection	ODS 1/2" H:70	106.060.B03.000.002	Ø20 ST44-E275	1
2	Outlet Connection	ODS 1/2" H:70	106.060.B03.000.002	Ø20 ST44-E275	1
3	Oil Return Connection	SAE 3/8" H:51,5	106.060.Y02.001.003	S235	1
4	Cover	Ø114x4 H:20	202.033.114.001.010	P355GH	1
5	Shell	Ø114x3 H:210	104.060.002.114.001	EN 10217-3 P355NH	1
6	Head	Ø114x4 H:32	101.033.114.001.000	P355GH-EN10028-2	1
7	Knock-out bolt	M10x20	109.100.020.999.C01	DIN 7991 - 10.9	1
8	Base Plate	Ø90x2,5 H:13,5	105.004.085.001.001	EN 10111 - DD-13	1

GENERAL NOTES

- Max. allowable operating pressure (PS) according to the temperature range;
- 1) Allowable operating temperature : min. -20C° / max. +130C° PS1 = 30 Bar
- 2) Allowable operating temperature : min. -20C° / max. -40C° PS2 = 22 Bar
- Unless otherwise specified dimensions in MM
- Unless otherwise specified do not scale
- Unless otherwise specified tube must be clean&free from burrs inside&outside&uitable for soldering
- Unless otherwise specified do not scale indicated thickness are min. after forming or machining
- Unless otherwise specified dimension tolerances according to EN 113445-4

REVISIONS

No	Details Of Change	Date	By
01	Tam boy ayarlandı ve ayak tipi değiştirildi	09.06.2022	M.ABDULAZİZ
02			
03			

RELATED DRAWINGS

No	Description	Drawing No
01		
02		

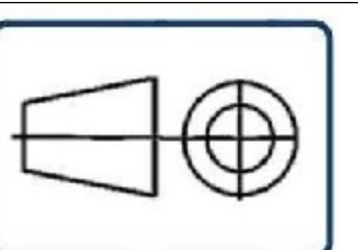

No	Assembly Codes	Qty
1	M005.000263	1

We reserve all rights in this document and in the information contained therein. Reproduction use or disclosure to third parties without express authority is strictly forbidden.