

Product specification

Technical data

Max. temperature on thermostatic element:

MAH: 150 °C / 302 °F

K: 150 °C / 302 °F

N: 100 °C / 210 °F

Max. temperature on valve body: 110 °C / 230 °F

Max. working pressure: 49 bar / 711 psig.

Max. test pressure: 54 bar / 783 psig.

Table 1: Standard evaporating temperature ranges

Charge	Temperature range
MAH	-30 – 15 °C / -22 – 60 °F
N	-40 – 10 °C / -40 – 50 °F without MOP
K	-25 – 10 °C, MOP 15 °C / -15 – 50 °F, MOP 60 °F

Table 2: Max. operating pressure

Refrigerant	Range K: -25 – 10 °C / -15 – 50 °F, MOP +15 °C / +60 °F
	MOP point in evaporating pressure pe
R410A	11.4 bar / 165 psig
R22	6.9 bar / 100 psig
R134a	3.8 bar / 55 psig
R407C	6.6 bar / 95 psig
R404A/ R507	8.3 bar / 120 psig

i NOTE:

MOP for R32, R452B, R454B, R1234ze, R407F, R407A and R290, please contact Danfoss for more info.

Table 3: Connections

Type	Inlet solder ODF [inch]	Inlet solder ODF [mm]	Outlet solder ODF [inch]	Outlet solder ODF [mm]
TGE 10	3/8, 1/2, 5/8, 7/8	10, 12, 16, 22	5/8, 7/8, 1 1/8	16, 22, 28
TGE 20	5/8, 7/8, 1 1/8	16, 22, 28	5/8, 7/8, 1 1/8, 1 3/8	16, 22, 28, 35
TGE 40	7/8, 1 1/8	22, 28	7/8, 1 1/8, 1 3/8	22, 28, 35

Table 4: Capillary tube length

Type	Capillary tube length	
TGE 10 / TGE 20	1.5 m	59 inch
TGE 40	3 m	118 inch

Valve options

In addition to the standard programme, variants of following options may be available:

- Refrigerants
- Evaporating temperature range
- MOP point
- Static superheat setting (0K – 8K / 0 – 14.4 °F)
- Mechanical connections
- Bleed function (15% or 30%)

i NOTE:

Please contact your nearest Danfoss sales office to discuss valve options.

Refrigerants

Refrigerants: R410A, R32, R452B, R454B, R22, R134a, R1234ze, R407F, R407A, R404A, R507, R407C and R290.

Thermostatic expansion valves, Type TGE

For other refrigerants, please contact Danfoss.

i NOTE:

This product is approved for R290, R32, R452B, R454B by ignition source assessment in accordance to standard EN ISO80079-36 .

Capacity table

Table 5: Rated capacity²⁾

Valve type	Orifice no.	Range N, K, MAH																							
		R410A		R32		R452B ⁴⁾		R454B ⁴⁾		R22		R134a		R1234ze		R407F		R407A		R404A / R507		R407C		R290	
		KW	TR	KW	TR	KW	TR	KW	TR	KW	TR	KW	TR	KW	TR	KW	TR	KW	TR	KW	TR	KW	TR	KW	TR
TGE 10	3	12	3.5	18	5	12	3.5	12	3.5	10	3	6	1.5	5	1.5	10	3	9	2.5	7	2	9	2.5	10	3
	4	16	4.5	24	7	16	4.5	18	5.0	14	4	8	2.5	7	2	14	4	12	3.5	9	2.5	13	3.5	14	4
	6	24	6.5	35	10	24	6.5	26	7.5	20	6	12	3.5	10	3	20	6	17	5	14	4	19	5	19	5
	8	32	9	47	13	32	9	35	10	27	7.5	17	4.5	14	4	27	7.5	23	6.5	18	5	25	7	25	7
	9	37	11	54	15	38	11	42	12	32	9	20	5.5	16	4.5	32	9	28	8	21	6	30	8.5	32	9
	11	45	13	68	19	46	13	49	14	38	11	24	7	20	5.5	40	11	34	10	26	7.5	36	10	36	10
	12.5	50	14	74	21	50	14	56	16	43	12	29	8	22	6	43	12	39	11	31	9	39	11	44	12
	16	60	17	87	25	60	17	67	19	50	14	35	9.5	27	7.5	50	14	46	13	35	10	49	14	50	14
673180 TGE 20	12.5	54	15	81	23	55	15	56	16	43	12	29	8	22	6	46	13	39	11	31	9	42	12	44	12
	16	68	19	102	29	68	19	74	21	54	15	37	10	27	7.5	57	16	50	14	39	11	53	15	54	15
	20	79	23	120	34	81	23	88	25	63	18	44	12	31	8.5	67	19	59	17	45	13	62	18	63	18
	21 ³⁾	91	26	135	38	98	28	102	29	75	21	51	15	39	11	82	23	72	21	53	15	77	22	75	21
TGE 40	26	110	31	165	47	117	33	120	34	92	26	61	17	49	14	95	27	80	23	64	18	84	24	92	26
	30	125	35	187	53	134	38	137	39	104	30	70	20	57	16	108	31	91	26	72	21	95	27	106	30
	40	161	46	236	67	172	49	179	51	134	38	87	25	72	20	138	39	116	33	92	26	121	34	133	38
	42	182	52	273	78	208	59	208	59	148	42	102	29	81	23	165	47	140	40	105	30	148	42	152	43

²⁾ The rated capacity is based on:

Evaporating temperature t_e : 4.4 °C / 40 °F

Condensing temperature t_c : 38 °C / 100 °F

Refrigerant temperature ahead of valve t_1 : 37 °C / 98 °F

³⁾ Contact Danfoss for more information

⁴⁾ New sales code numbers are on request.

Valve selection based on capacity calculation

As for extended capacity calculations and valve selection based on capacities and refrigerants, please refer to Coolselector[®]2. Rated and extended capacities are calculated with the Coolselector[®]2 calculation engine to ARI standards with the ASEREP equations based on laboratory measurements of selected valves.

Dimensions and weights

Figure 6: Type TGE 10, TGE 20 and TGE 40

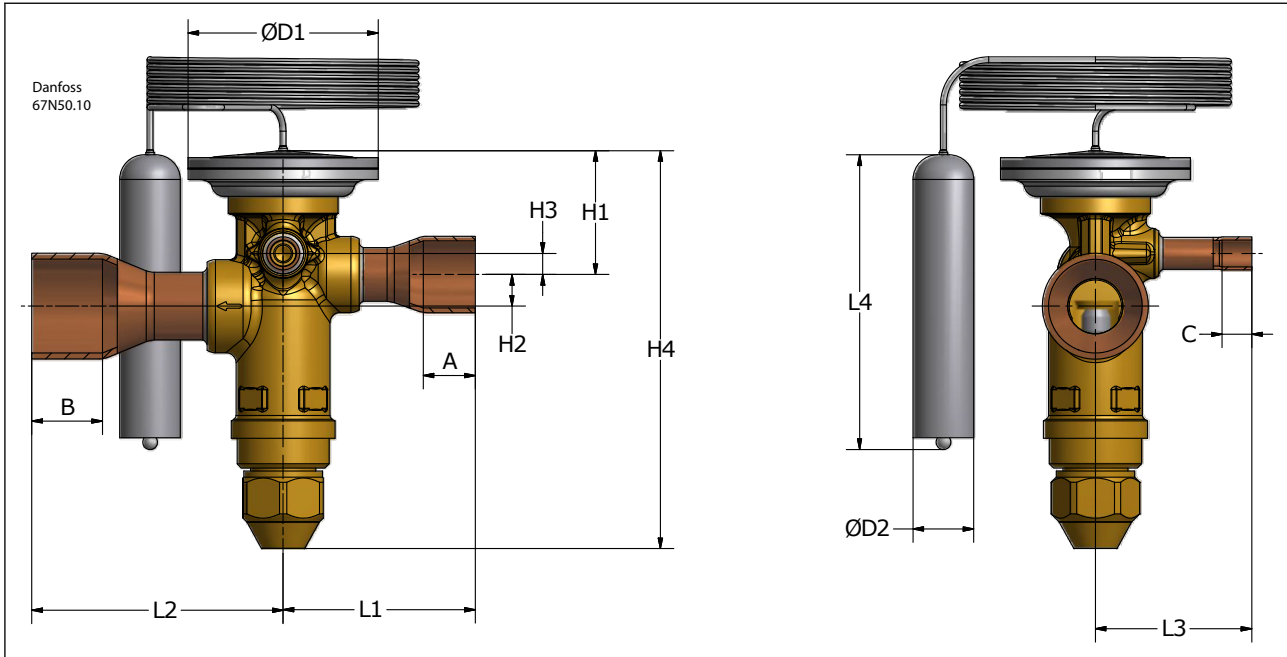

Table 6: Dimensions and weight in SI units

Type	Connections. ODF solder inlet x outlet x equalization		Capillary tube length [mm]	H1 [mm]	H2 [mm]	H3 [mm]	H4 [mm]	L1 [mm]	L2 [mm]	L3 [mm]	L4 [mm]	ØD1 [mm]	ØD2 [mm]	A [mm]	B [mm]	C [mm]	Weight [kg]
	[in.]	[mm]															
TGE 10	3/8 x 5/8 x 1/4	10 x 16 x 6	1.5	28.5	7.5	5.0	95.0	41.5	45.5	37.0	70	45	14.35	9.0	12	7	0.37
	1/2 x 5/8 x 1/4	12 x 16 x 6	1.5	28.5	7.5	5.0	95.0	41.5	45.5	37.0	70	45	14.35	10	12	7	0.37
	1/2 x 7/8 x 1/4	12 x 22 x 6	1.5	28.5	7.5	5.0	95.0	41.5	59.5	37.0	70	45	14.35	10	17	7	0.37
	5/8 x 5/8 x 1/4	16 x 16 x 6	1.5	28.5	7.5	5.0	95.0	45.5	45.5	37.0	70	45	14.35	12	12	7	0.37
	5/8 x 7/8 x 1/4	16 x 22 x 6	1.5	28.5	7.5	5.0	95.0	45.5	59.5	37.0	70	45	14.35	12	17	7	0.37
	5/8 x 1 1/8 x 1/4	16 x 28 x 6	1.5	28.5	7.5	5.0	95.0	45.5	59.5	37.0	70	45	14.35	12	20	7	0.37
	7/8 x 7/8 x 1/4	22 x 22 x 6	1.5	28.5	7.5	5.0	95.0	45.5	59.5	37.0	70	45	14.35	12	17	7	0.37
	7/8 x 1 1/8 x 1/4	22 x 28 x 6	1.5	28.5	7.5	5.0	95.0	45.5	59.5	37.0	70	45	14.35	12	20	7	0.37
TGE 20	5/8 x 5/8 x 1/4	16 x 16 x 6	1.5	32.0	9.0	8.0	121	48.0	62.0	40.5	78	53	19.20	12	12	7	0.57
	5/8 x 7/8 x 1/4	16 x 22 x 6	1.5	32.0	9.0	8.0	121	48.0	62.0	40.5	78	53	19.20	12	17	7	0.57
	5/8 x 1 1/8 x 1/4	16 x 28 x 6	1.5	32.0	9.0	8.0	121	48.0	66.0	40.5	78	53	19.20	12	20	7	0.57
	7/8 x 7/8 x 1/4	22 x 22 x 6	1.5	32.0	9.0	8.0	121	62.0	62.0	40.5	78	53	19.20	17	17	7	0.57
	7/8 x 1 1/8 x 1/4	22 x 28 x 6	1.5	32.0	9.0	8.0	121	62.0	66.0	40.5	78	53	19.20	17	20	7	0.57
	7/8 x 1 3/8 x 1/4	22 x 35 x 6	1.5	32.0	9.0	8.0	121	62.0	66.0	40.5	78	53	19.20	17	24	7	0.57
	1 1/8 x 1 1/8 x 1/4	28 x 28 x 6	1.5	32.0	9.0	8.0	121	62.0	66.0	40.5	78	53	19.20	20	20	7	0.57
	1 1/8 x 1 3/8 x 1/4	28 x 35 x 6	1.5	32.0	9.0	8.0	121	62.0	66.0	40.5	78	53	19.20	20	24	7	0.57
TGE 40	7/8 x 7/8 x 1/4	22 x 22 x 6	3	39.0	15	11	148	65.5	69.5	43.5	78	60	19.20	17	20	7	0.93
	7/8 x 1 1/8 x 1/4	22 x 28 x 6	3	39.0	15	11	148	65.5	69.5	43.5	78	60	19.20	17	20	7	0.93
	7/8 x 1 3/8 x 1/4	22 x 35 x 6	3	39.0	15	11	148	65.5	74.5	43.5	78	60	19.20	17	25	7	0.93
	1 1/8 x 1 1/8 x 1/4	28 x 28 x 6	3	39.0	15	11	148	69.5	69.5	43.5	78	60	19.20	20	20	7	0.93
	1 1/8 x 1 3/8 x 1/4	28 x 35 x 6	3	39.0	15	11	148	69.5	74.5	43.5	78	60	19.20	20	25	7	0.93

673180

Ordering
Table 8: R410A/R32, Range N -40 – 10 °C / -40 –50 °F, OS = 4 K / 7.2 °F

Valve type	Orifice no.	Rated capacity R410A		Rated capacity R32		Connections solder ODF		Code no. Multi pack
		[KW]	[TR]	[KW]	[TR]	Inlet x Outlet [inch]	Pressure equalization [inch]	
TGE 10	3	12	3.5	18	5	3/8 x 5/8	1/4	067N3150
TGE 10	3	12	3.5	18	5	1/2 x 5/8	1/4	067N3151
TGE 10	4	16	4.5	24	7	1/2 x 7/8	1/4	067N3152
TGE 10	6	24	6.5	35	10	1/2 x 5/8	1/4	067N3153
TGE 10	6	24	6.5	35	10	1/2 x 7/8	1/4	067N3154
TGE 10	6	24	6.5	35	10	5/8 x 7/8	1/4	067N3155
TGE 10	8	32	9	47	13	1/2 x 5/8	1/4	067N3293
TGE 10	8	32	9	47	13	5/8 x 7/8	1/4	067N3156
TGE 10	9	37	11	54	15	5/8 x 7/8	1/4	067N3296
TGE 10	11	45	13	68	19	5/8 x 7/8	1/4	067N3157
TGE 10	12.5	50	14	74	21	5/8 x 7/8	1/4	067N3410
TGE 20	12.5	54	15	81	23	5/8 x 7/8	1/4	067N3159
TGE 40	26	110	31	165	47	1 1/8 x 1 1/8	1/4	067N3234

The rated capacity is based on:

 Evaporating temperature t_e : 4.4 °C / 40 °F

 Condensing temperature t_c : 38 °C / 100 °F

 Refrigerant temperature ahead of valve t_1 : 37 °C / 98 °F

Table 9: R410A, Range N -40 – 10 °C / -40 –50 °F, OS = 4 K / 7.2 °F

Valve type	Orifice no.	Rated capacity		Connections solder ODF		Code no. Multi pack
		[KW]	[TR]	Inlet x Outlet [inch]	Pressure equalization [inch]	
TGE 10	11	45	13	5/8 x 1 1/8	1/4	067N3158
TGE 10	16	60	17	7/8 x 1 1/8	1/4	067N3411
TGE 20	12.5	54	15	5/8 x 1 1/8	1/4	067N3160
TGE 20	12.5	54	15	7/8 x 7/8	1/4	067N3231
TGE 20	12.5	54	15	7/8 x 1 1/8	1/4	067N3232
TGE 20	16	68	19	5/8 x 1 1/8	1/4	067N3161
TGE 20	16	68	19	7/8 x 1 1/8	1/4	067N3162
TGE 20	20	79	23	7/8 x 1 1/8	1/4	067N3163
TGE 20	20	79	23	7/8 x 1 3/8	1/4	067N3164
TGE 20	21	91	26	7/8 x 1 1/8	1/4	067N3272
TGE 40	26	110	31	7/8 x 1 3/8	1/4	067N3165
TGE 40	26	110	31	1 1/8 x 1 3/8	1/4	067N3166
TGE 40	30	125	35	1 1/8 x 1 3/8	1/4	067N3168
TGE 40	40	161	46	1 1/8 x 1 3/8	1/4	067N3169
TGE 40	42	182	52	1 1/8 x 1 3/8	1/4	067N3400

The rated capacity is based on:

 Evaporating temperature t_e : 4.4 °C / 40 °F

 Condensing temperature t_c : 38 °C / 100 °F

 Refrigerant temperature ahead of valve t_1 : 37 °C / 98 °F

Table 10: R410A, Range K -25 – 10 °C / -15 – 50 °F with MOP 15 °C / 60 °F, OS = 4 K / 7.2 °F

Valve type	Orifice no.	Rated capacity		Connections solder ODF		Code no. Multi pack
		[KW]	[TR]	Inlet x Outlet [inch]	Pressure equalization [inch]	
TGE 10	3	12	3.5	3/8 x 5/8	1/4	067N3000
TGE 10	3	12	3.5	1/2 x 5/8	1/4	067N3001
TGE 10	4	16	4.5	1/2 x 7/8	1/4	067N3002
TGE 10	6	24	6.5	1/2 x 5/8	1/4	067N3003
TGE 10	6	24	6.5	5/8 x 7/8	1/4	067N3005