

FR11G

Universal Compressor

R134a

220-240V 50Hz

Data Sheet (Replaces CG.43.E1.02)

General

Compressor	FR11G
Code number	103G6980

Application

Application		LBP/HBP	
Evaporating temperature range	°C	-30 to 5	
Voltage range	V/Hz	LBP: 187 - 254 /50	
		HBP: 198 - 254 /50	
Motor type		RSIR/CSIR	
Max. ambient temperature	°C	43	
Comp. cooling at ambient temp.	32°C	LBP: F ₂	
		HBP: F ₂	
		38°C	LBP: F ₂
		HBP: F ₂	
	43°C	LBP: F ₂	
		HBP: F ₂	

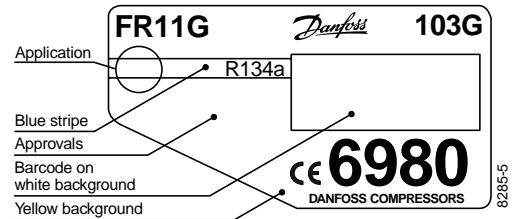

- S = Static cooling normally sufficient
- O = Oil cooling
- F₁ = Fan cooling 1.5 m/s
(compressor compartment temperature equal to ambient temperature)
- F₂ = Fan cooling 3.0 m/s necessary

Design

Displacement	cm ³	11.15
Oil quantity	cm ³	450
Maximum refrigerant charge	g	900
Free gas vol. in compressor	cm ³	1350
Weight without electrical equipment	kg	10.6

Motor

Motor size	watt	275
LRA (rated after 4 sec. UL984) LST/HST	A	10.3/10.0
Cut-in current LST/HST	A	15.0/10.0
Resistance, main and start winding (25°C)	Ω	7.3/12.0
Approvals		EN 60335-2-34, CCIB

Dimensions

Height	mm	A	196
		B	191
Suction connector	location/I.D. mm	C	8.2 ±0.09
Process connector	location/I.D. mm	D	6.2 ±0.09
Discharge connector	location/I.D. mm	E	6.2 ±0.09
Compressors on a pallet	pcs.		80

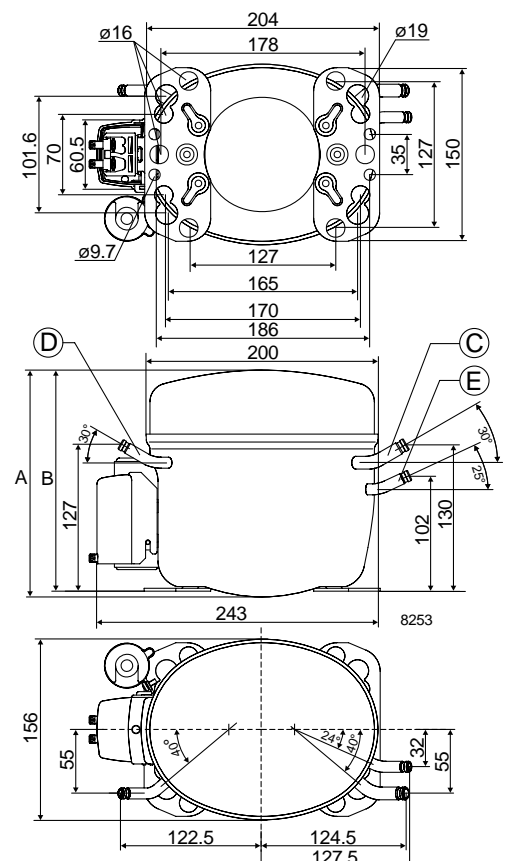

Capacity (EN 12900/CECOMAF)

watt

Comp.°C	-30	-25	-23.3	-20	-15	-10	-5	0	5
FR11G	115	170	191	233	307	395	501	628	780

Capacity (ASHRAE)

watt

Comp.°C	-30	-25	-23.3	-20	-15	-10	-5	0	5
FR11G	141	209	235	287	378	487	619	777	966

Power consumption

watt

Comp.°C	-30	-25	-23.3	-20	-15	-10	-5	0	5
FR11G	165	202	215	240	278	317	357	400	445

Current consumption

A

Comp.°C	-30	-25	-23.3	-20	-15	-10	-5	0	5
FR11G	1.52	1.59	1.63	1.69	1.81	1.95	2.10	2.26	2.42

COP (EN 12900/CECOMAF)

W/W

Comp.°C	-30	-25	-23.3	-20	-15	-10	-5	0	5
FR11G	0.70	0.84	0.89	0.97	1.11	1.25	1.40	1.57	1.75

COP (ASHRAE)

W/W

Comp.°C	-30	-25	-23.3	-20	-15	-10	-5	0	5
FR11G	0.86	1.04	1.09	1.20	1.36	1.54	1.73	1.94	2.17

Test conditions
 Condensing temperature 55°C
 Ambient and suction gas temp. 32°C
 Liquid temperature 55°C
 Fan cooling F₂, 220V 50Hz

EN 12900/CECOMAF
 55°C
 32°C
 55°C

ASHRAE
 55°C
 32°C
 32°C

Accessories

Devices		Fig.	FR11G
PTC starting device	6.3 mm spades	a1	103N0011
	4.8 mm spades		103N0018
Starting relay		a2	117U6010
Cover		b	103N2010
Starting capacitor 80 µF		c	117U5015
Cord relief		d	103N1010
Protection screen for PTC		g	103N0476
Mounting accessories			
Bolt joint for one compressor			118-1917
Bolt joint in quantities			118-1918
Snap-on in quantities			118-1919

