



מקט דיין: 7535

Specifications

AC Axial Fan

Model : YWF6E-450

Type : S-B5L

Coding : E04150772

Version: V1.0

Date : 2022.09.02

Version	Status	Version update instructions	Date	DRN BY	CHK BY
V1.0	Effective	Initial release	2022-09-02	JX. Chen	XQ. Chen



Standards

- GB12350 《Safety Requirements of small Power motors》
- EN60335-1 《Safety Requirements of Household of Similar Electrical Appliances》
- The level of balance is in accordance with ISO 1940, G4.0
- Vibration testing and velocity is performed according to JB/T8689.
- This product is certified by China CCC and EU CE
- ISO 9001 quality system certification
- Standard of noise test: ISO 13347 《Determination of fan sound power levels under standardized laboratory conditions》
- The fan performance data is accurate and reliable, conforming to GB/T1236-2017 and 《Industrial fans-performance testing using standardize dairways》 in ISO5801-2007 standards.

Product Drawings

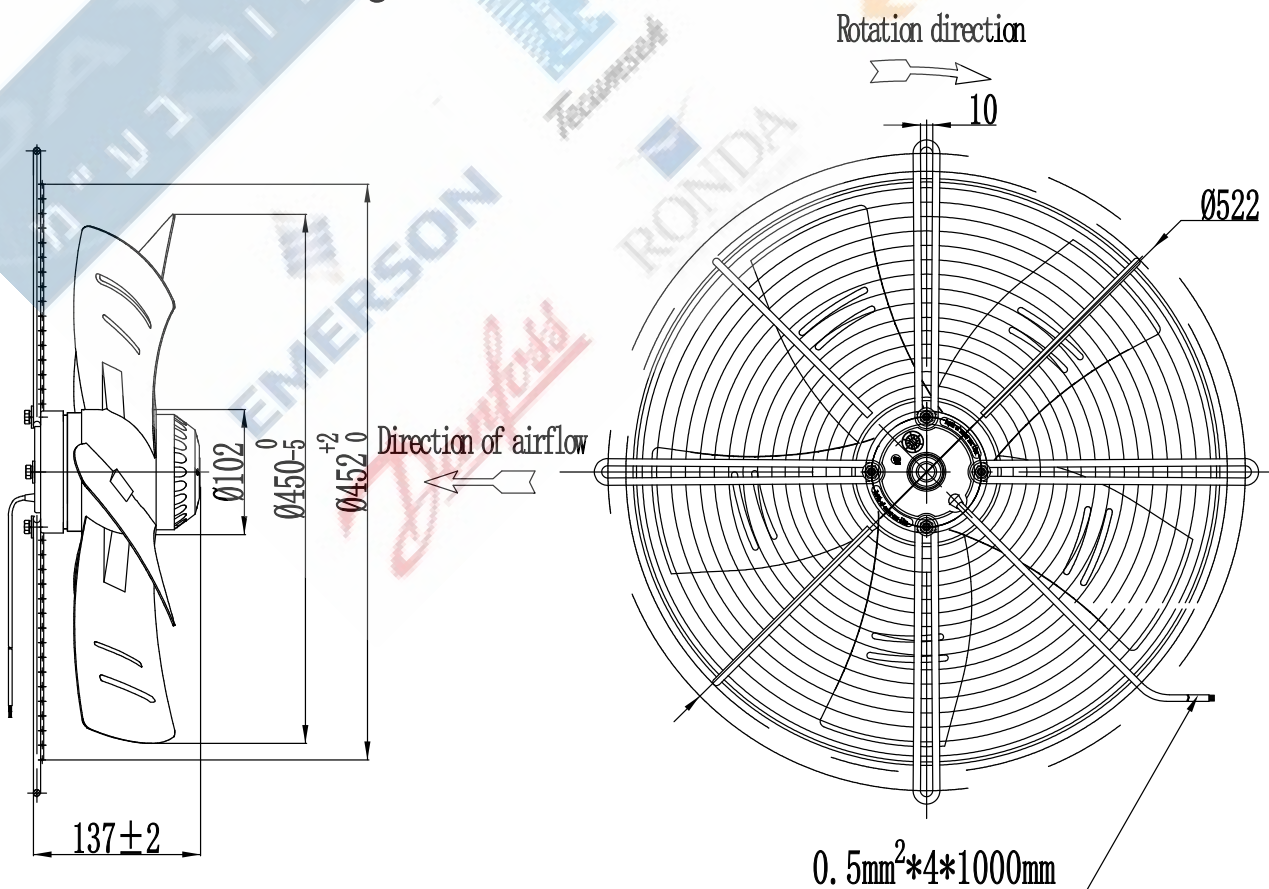



Technical Parameters

Power supply	Phase	1
Frequency	Hz	50
Wiring		-
Capacitance	μ F	6
Input Voltage	V	230
Input Current	A	0.79
Input Power	W	155
Rated Speed	r/min	930
Fan Noise	dB(A)	55
Fan Steering		Counterclockwise(From the motor)
Fan Life	h	40000
Fan Weight	kg	-
Protection Level		IP54
Insulation Class		F
Balance Level		G4.0
Ambient Temperature	$^{\circ}$ C	-40~+60
Environment Humidity		\leq 90%RH
Impeller Material		Metal
Spray Color		-
Operating Status		S1



Label

External Rotor Axial Fan					CE
YWF6E-450	S-B5L	E04150772			EAC
230V	50Hz	0.79A	155W	6 μ F/450V	
930r/min	3608m ³ /h	60Pa	CL.F	Date:2022.XX	

Product wiring diagram

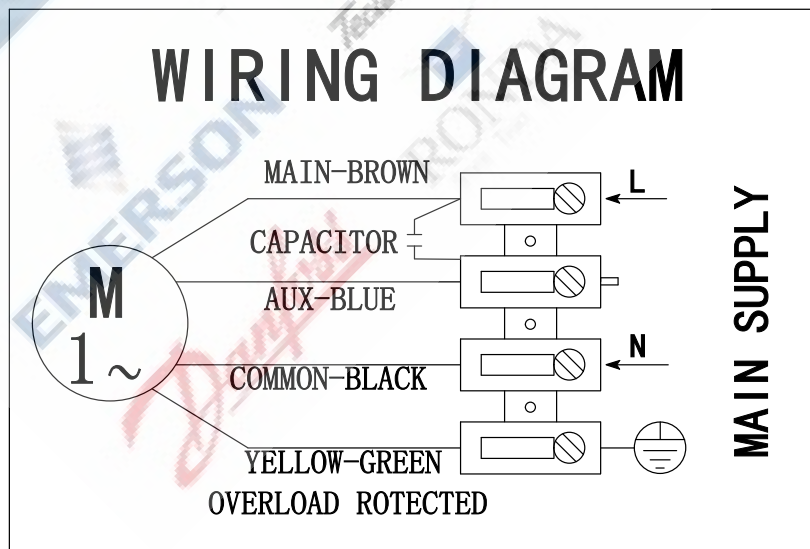



Product Performance

Airflow—static pressure curve:

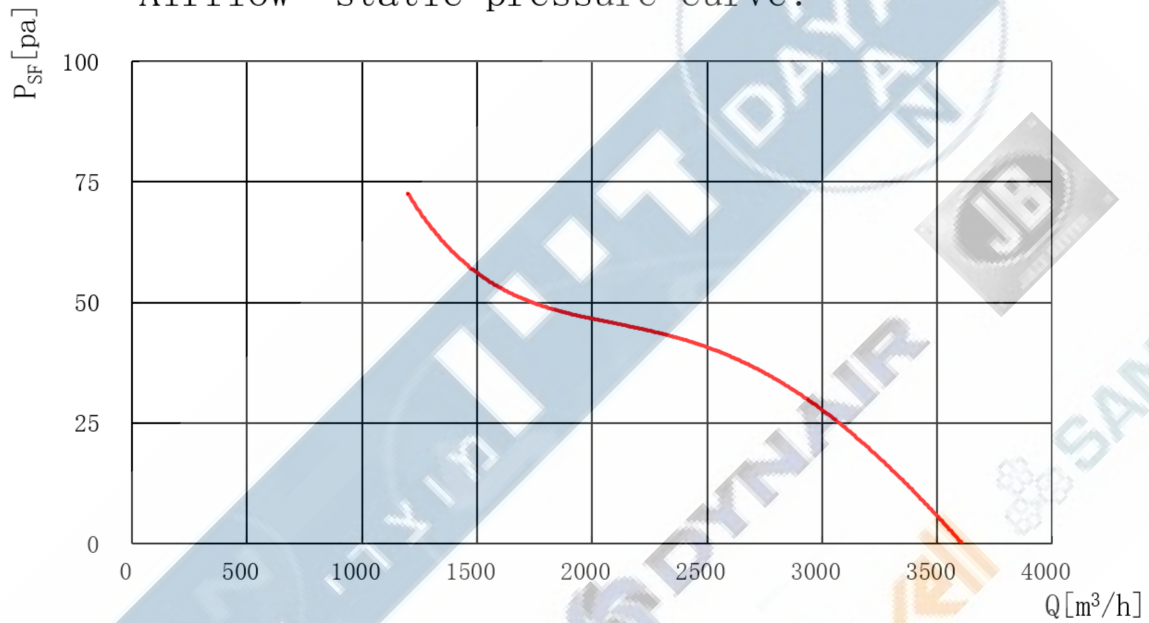

St. P.	Air Flow	Speed	Voltage	Freq.	Current	Power
Pa	m3/h	RPM	V	Hz	Amp	W
0	3608	947	227	50	0.82	170
16	3304	939	230	50	0.85	180
28	3000	933	228	50	0.85	180
36	2704	928	231	50	0.87	187
43	2404	923	231	50	0.88	190
47	2100	922	233	50	0.90	197
47	1799	918	232	50	0.89	195
57	1505	914	232	50	0.91	200
72	1200	896	233	50	0.94	210
80	1004	891	236	50	0.97	218