



מקט דיין: 7553

# Specifications

AC Axial Fan

Model : YWF6E-550

Type : S-B5C

Coding : E04230056

Version: V1.0

Date : 2022.09.11

Version	Status	Version update instructions	Date	DRN BY	CHK BY
V1.0	Effective	Initial release	2022-09-11	ZH. Shao	XQ. Chen





## Technical Parameters

Power supply	Phase	1
Frequency	Hz	50
Wiring		-
Capacitance	$\mu F$	6
Input Voltage	V	230
Input Current	A	1.0
Input Power	W	220
Rated Speed	r/min	880
Fan Noise	dB(A)	60
Fan Steering		Counterclockwise(From the motor)
Fan Life	h	40000
Fan Weight	kg	-
Protection Level		IP54
Insulation Class		F
Balance Level		G4.0
Ambient Temperature	$^{\circ}C$	-40~+60
Environment Humidity		$\leq 90\%RH$
Impeller Material		Metal
Spray Color		-
Operating Status		S1



# Label

External Rotor Axial Fan					<b>CE</b>
YWF6E-550	S-B5C	E04230056			<b>EAC</b>
230V	50Hz	1.0A	220W	6 $\mu$ F/450V	
880r/min	5720m <sup>3</sup> /h	85Pa	CL. F	Date:2022. XX	

# Product wiring diagram

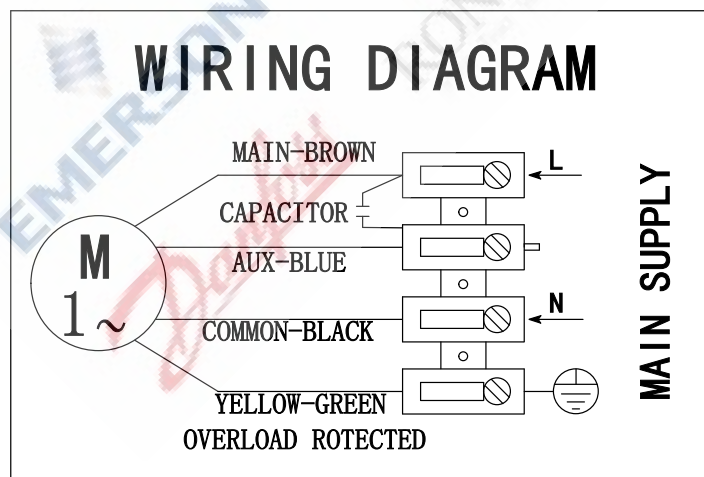





# Product Performance

Airflow-static pressure curve:

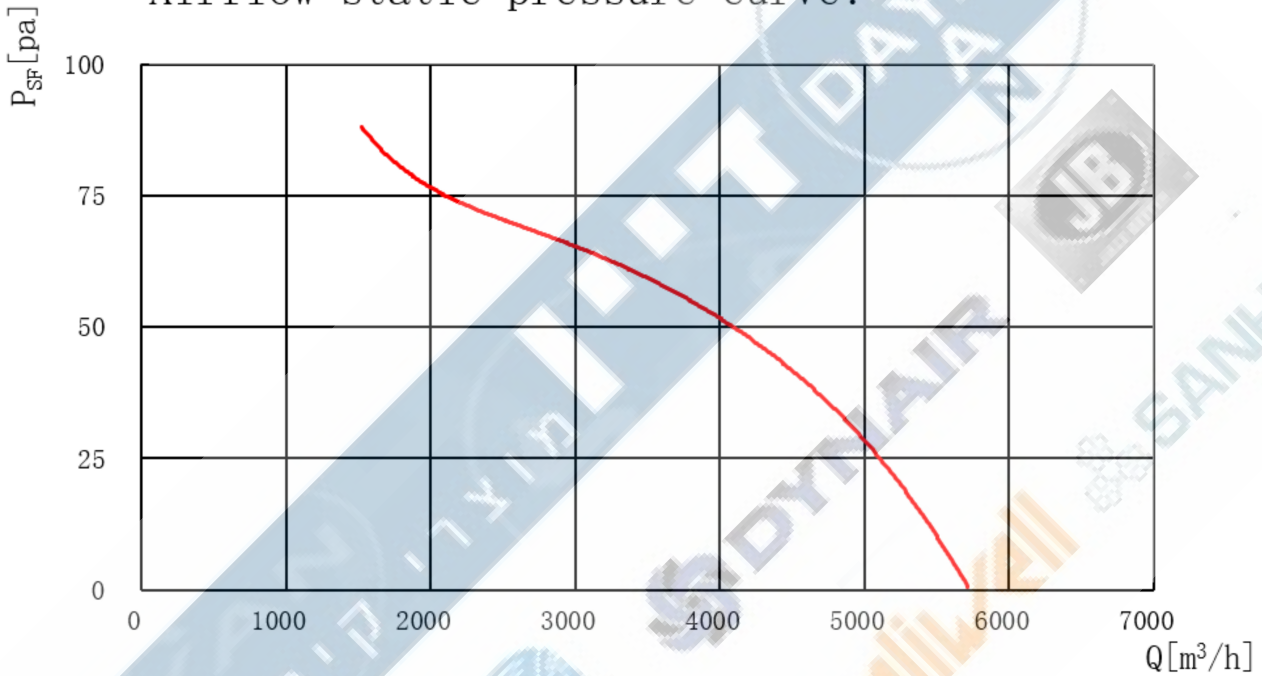

St. P.	Air Flow	Speed	Voltage	Freq.	Current	Power
Pa	m3/h	RPM	V	Hz	Amp	W
0	5717	922	231	50	0.85	191
10	5501	920	230	50	0.88	198
29	5001	905	232	50	0.95	214
41	4502	894	230	50	0.99	222
52	4001	887	232	50	1.02	230
60	3501	874	230	50	1.06	237
64	3002	863	232	50	1.10	247
71	2502	855	231	50	1.12	252
76	2002	853	229	50	1.13	251
88	1526	817	231	50	1.23	275