

CSSSE3600018

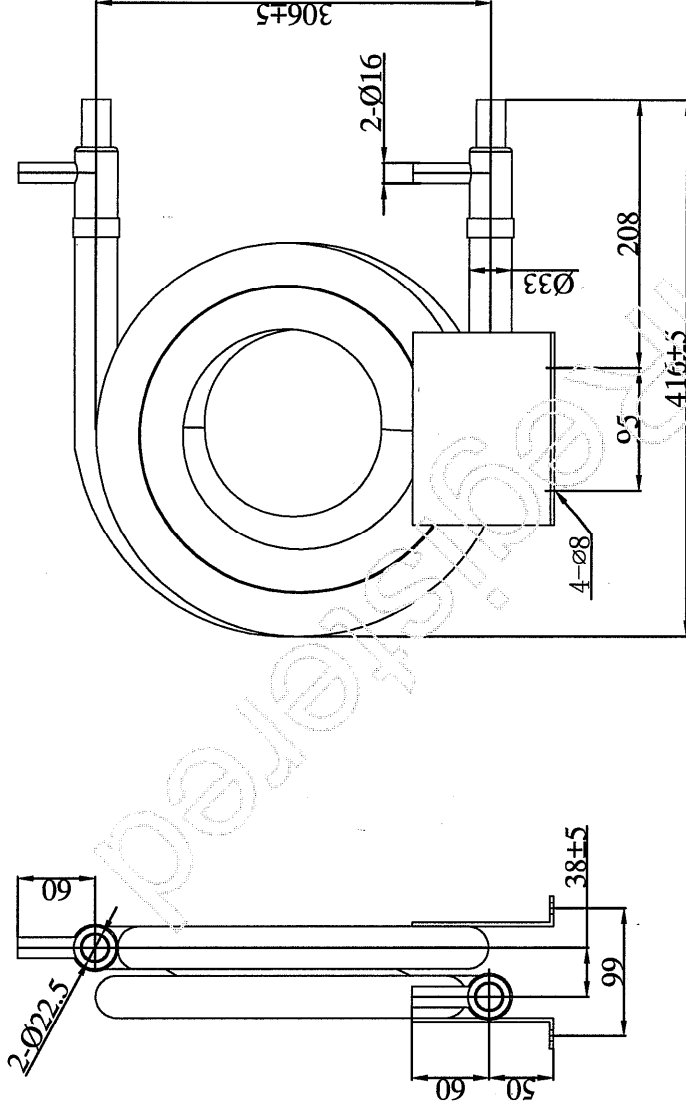

Quality Data:

- ① All welded place should be well welded. Any defect on small holes and leaks is unacceptable.
- ② Inner tube was treated by oxidize resistance.
- ③ Heat exchanger is black painted except 30mm cylinder from connections end.
- ④ Each end connection should be sealed by a plastic cap or welding.
- ⑤ Design working pressure: refrigerant side: 430psi, water side: 220psi;
- ⑥ After final assembly, each part must be fill 0.05Mpa N2 gas through refrigeration circuit.
- ⑦ Any non-indicated dimensions and tolerances are subject to GB/T1804 V degree.

MARK NO.		REVISION	DESIGNER	CHECK	RECHECK	PROCESS
		修改				
SIGNATURE		DATE	STANDARD	AUTHORIZED	Q/TY	DATE
						2009.08.05
DRAWING MARK		WEIGHT	SCALE	TOTAL: 1 PAGE 1 PAGE		
Coaxial Heat Exchanger		MATERIAL: OUTER TUBE: STEEL				
		INNER TUBE: CU-PRO-NICKEL				
杭州沈氏换热器有限公司		SS-0360GN-W				
Hangzhou Shenshi Heat Exchanger Co., Ltd.		36-3820/2-16/2-22.5				
		CSSE3600018				

8928