

发行编号 Publish No. :	LGETA-180110-2110
发布日期 Publish Date:	2018.01.10
版本号 Edition No. :	REV. 0
修订日期 Modify Date:	-

1. 额定规格(Specification)

1.1 压缩机(Compressor)

1	压缩机型号名 Compressor Model Name	ABT061YTA
2	压缩机类型 Compressor Type	密封电动机-压缩机 Hermetic Motor Compressor
3	压缩方式 Compression Type	涡旋式 Scroll
4	排气量 Displacement	59.2 cm ³ / rev
5	制冷剂 Refrigerant	R410A
6	安全审核 Safety approval	VDE
7	冷冻机油/注油量 Oil / Oil Charging Amount	POE or PVE/ 1,360cc
8	充氮压力 Nitrogen Gas Holding Pressure	0.8 ± 0.2 kg/cm ² G
9	喷涂 Painting	黑色 Black Color Paint
10	净重(含油) Net Weight (Including Oil, Reference)	33.0 kg
11	吸气管内径 Suction Tube I.D.	Φ 22.4 ± 0.1 mm
12	排气管内径 Discharge Tube I.D.	Φ 12.88 ± 0.1 mm

1.2 Motor

1	电机类型/启动类型 Motor Type / Starting Type	三相感应电机 Three Phase Induction Motor	
2	电极/额定输出 Pole / Rated Output	2极(POLE) / 4,200[W]	
3	电源 Power Source	3 Ph - 380/420volt - 50 Hz	
4	额定转速 Rated Revolution	2,920 rpm	
5	绝缘等级 Insulation Class	B 级(CLASS)	
6	绕线电阻(25℃) Winding Resistance (at 25℃)	U - V	2.33 ± 7% ohm
		V - W	2.28 ± 7% ohm
		W - U	2.40 ± 7% ohm

1.3 Safety Device

Device	Operation Range	Type
Pressure Relief Valve (Pressure Diff.)	38.7~45.7 kgf/cm ² G	Internal type

发行编号 Publish No. :	LGETA-180110-2110
发布日期 Publish Date:	2018.01.10
版本号 Edition No. :	REV. 0
修订日期 Modify Date:	-

1.4 性能(Performance)

电压 Voltage	at 380V
制冷量 Cooling Capacity (95%↑)	51,500 Btu/h
	15,093 W
输入功率 Power Input (105%↓)	4,725 W
E.E.R (95%↑)	10.9 Btu/W·h
工作电流 Running Current(reference)	8.0 [A]
堵转电流 Locked Rotor Ampere	63 [A]
噪音 Noise	Max 76dB(A)
振动 Vibration	Max 50 μ m

启动 Starting Condition	启动电压 Starting Voltage	压力条件 Pressure Condition
标准启动 at Normal Condition	额定电压的 90% start at 90% of Rated Voltage (342V)	Ps/Pd= 17.14 / 17.14kg/cm ² G
超负荷启动 at Overload Condition	额定电压的 95% start at 95% of Rated Voltage (361 V)	Ps/Pd= 19.18 /19.18 kg/cm ² G

※ 制冷量测试工况 (Rating Conditions)

Cond. Temp. : 54.4 °C (130 °F)

Evap. Temp. : 7.2 °C (45 °F)

Return Gas Temp. : 18.3 °C (65 °F)

Liquid Temp. : 46.1 °C (115 °F)

Ambient Temp. : 35.0 °C (95 °F)

噪音与振动测量点 Noise & Vibration Measuring Points

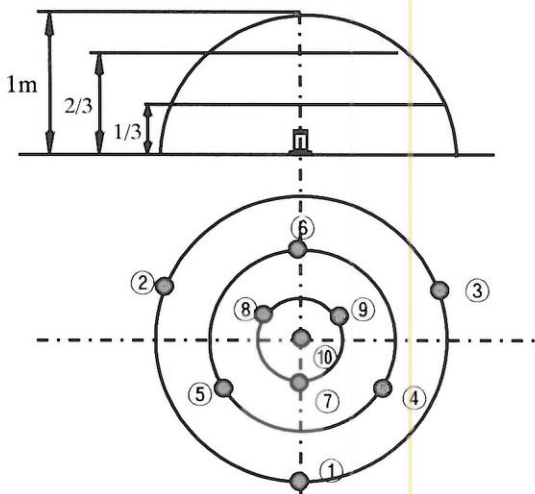

● 压缩机噪音根据ANSI/ARI 530-89 标准测量
Compressor sound is measured according to ANSI/ARI 530-89 standard.

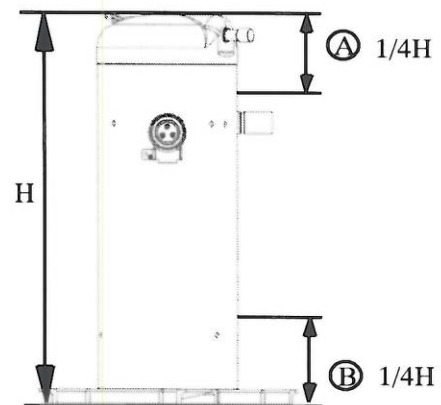

● 压缩机振动通过与机体A, B两点接触的振动计来测量

Compressor vibration is measured by a vibration meter which is contacted compressor body's (A) (B)

发行编号 Publish No. :	LGETA-180110-2110
发布日期 Publish Date:	2018.01.10
版本号 Edition No. :	REV. 0
修订日期 Modify Date:	-

1.5 其它 (Others)

泄漏强度压力 Leak Tight Pressure	高压端 High Pressure Side	40 kg/cm ² G
	低压端 Lower Pressure Side	- kg/cm ² G
液压强度压力 Hydrostatic Strength Pressure	高压端 High Pressure Side	170 kg/cm ² G
	低压端 Lower Pressure Side	85 kg/cm ² G
绝缘电阻 (采用 DC 500V Mega测试仪) Insulation Resistance (with 500V D.C Mega Tester)		50 MΩ Min.
耐电压 Withstand Voltage		2,200V 下 1秒钟泄漏电流小于5mA 2,200 V- 1 sec. Leakage Current is less than 5mA.
残余水分量/残余污物量 Residual Moisture / Residual Impurities		最大200mg / 最大 80mg 200 mg Max./ 80 mg Max.

1.6 电气零件 (Electrical Component)

零件名(Part Name)	规格 (Specification)
运转电容(RUNNING CAPACITOR)	-
过载保护器(O.L.P)	内置 (Internal Type)

2. 部件清单 (Delivered Parts List)

部件名 Parts Name	类型(型号) Type (Model)	数量 Quantity	部件图纸号码 (LG) Parts' Dwg . NO.(LG)	提供 Supply	
				YES	NO
压缩机(Compressor)	ABT061YTA	1	-	YES	NO
过载保护器(O.L.P)	内置	1	-	YES	NO
接线保护盒(Cover, Terminal)	-	1	MCK42672702	YES	NO
保护盒衬垫(Gasket)	-	1	MDS42672602	YES	NO
防振胶垫 (Grommet)	-	4	4022U-L004F	YES	NO
接地螺钉 (Screw,Taptite)	-	1	FAB32598601	YES	NO
套管(Sleeve , Grommet)	-	4	4816U-L001E	YES	NO

※ 参考附录 (附件图) Refer to Attachments (Accessory Parts Drawings.)

※ This guide contains many important safety messages.
Always read and obey all safety messages.

发行编号 Publish No. :	LGETA-180110-2110
发布日期 Publish Date:	2018.01.10
版本号 Edition No. :	REV. 0
修订日期 Modify Date:	-

▲ WARNING

You can be killed or seriously injured if you don't follow instructions.

3. 使用界限 (Operating Limit)

排气压力 (Discharge Pressure)	[kg/cm ² G]	45 Max
吸气压力 (Suction Pressure)	[kg/cm ² G]	2.6 ~ 11.0
电机绕组温度 (Motor Coil Temp.)	[°C]	135 Max
排气温度 (Discharge Temp.)	[°C]	130 Max

制冷剂注入量[g] Refrigerant Charge Limit	5,200g(Cooling Only) / 3,900g(Heat Pump) Max.
回流液体 Continuous Flood Back	储液器前的回流液体量不应超过制冷循环系统中制冷剂总量的10% Continuous Flood Back before the accumulator should not be more than 10% of the total circulation quantity of refrigerant.
开 / 停 间歇与次数 On/Off Interval & Cycles	间歇 : 开 / 停 = 3分钟 / 3分钟 次数 : 20,000次以下 On / Off = 3 Minutes / 3 Minutes 20,000 Cycles or less
电压范围 Voltage Range	¹⁾ 额定电压 ± 10% Rated Voltage ± 10 %
频率范围 Frequency Range	额定频率 ± 2% Rated Frequency ± 2 %
运转时压力差 Compression Ratio in Operating	运转时压缩比应在6.7以下,但3分钟启动的情况除外 The Compression ratio in operating shall be 6.7 or less , except 3 minutes starting period.
启动时压力差 Pressure Difference at Starting	启动时, 排气压力与吸气压力相平衡 When starting, discharge pressure is balanced with suction pressure.
倾斜 Tilt in Operation	使用时, 压缩机的倾斜角度应在 3° 以内 The allowable tilt of the compressor in operation shall be 3° or less.
管压 Pipe Stress	不允许给排气管和吸气管任何强制外力, 管路设计应力在起停时 300kgf/cm ² 以下, 运转时 153kgf/cm ² 以下 Don't allow any force on discharge & suction pipe . The piping stress must be less than 300kgf/cm ² at starting and stopping. And less than 153kgf/cm ² at running.
接地连接 Earth Connection	仅带有接地系统压缩机使用 Use compressor with grounded system only.
冷媒回收 Pump Down	长时间真空运转会导致压缩机损坏, Pump Down时间不能超过60s. Deep vacuum operation cause a serious damage to compressor. Pump Down operation time is allowed to less than 60 second.

¹⁾ Voltage measured at hermetic terminal.

发行编号 Publish No. :	LGETA-180110-2110
发布日期 Publish Date:	2018.01.10
版本号 Edition No. :	REV. 0
修订日期 Modify Date:	-

*** 产品标签 LABEL ***



[UNIT : mm]

All safety messages will identify the hazard, tell you how to reduce the chance of injury, and tell you what can happen if the instructions are not followed. You are strongly advised to follow these safety instructions.

Note



This is the Safety alert symbol. It indicates a hazardous situation which, if not avoided, could result in death or serious injury.



This is the Electric shock hazard symbol. It indicates a hazardous situation which, if not avoided, could result in the electric shock.



This is the Getting burnt symbol. It indicates a hazardous situation which, if not avoided, could cause fire.



This is the Explosion or Fire symbol. It indicates a hazardous situation which, if not avoided, could cause explosion or fire.

发行编号 Publish No. :	LGETA-180110-2110
发布日期 Publish Date:	2018.01.10
版本号 Edition No. :	REV. 0
修订日期 Modify Date:	-

3. 使用界限 (Operating Limit)

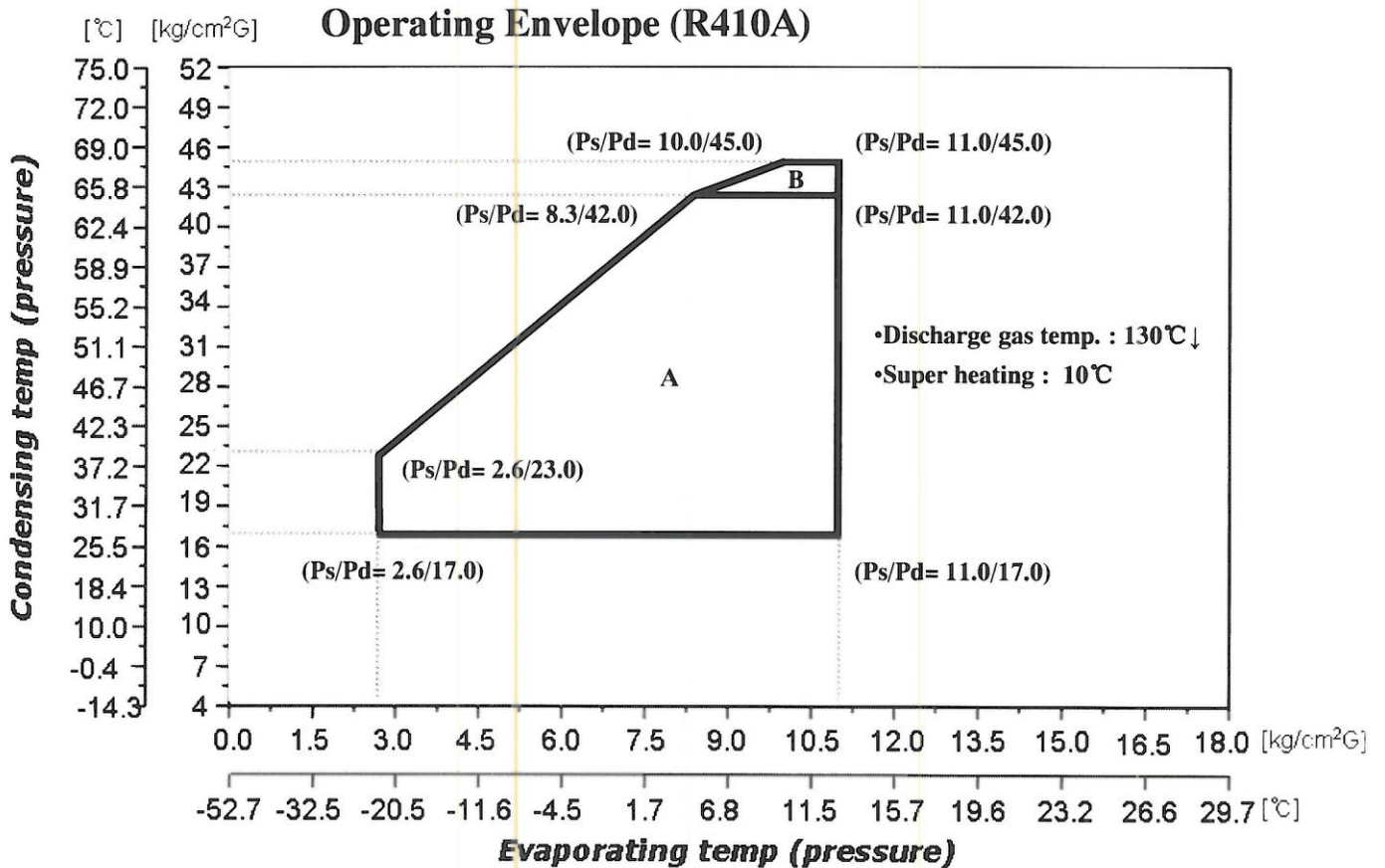

Area A : Normal Operating Zone

Area B : Tropical Model Zone

- Discharge pressure should be controlled below 45kg/cm²G.
(Have to install high pressure switch 45kg/cm²G ↓)

发行编号	Publish No. :	LGETA-180110-2110
发布日期	Publish Date:	2018.01.10
版本号	Edition No. :	REV.0
修订日期	Modify Date:	-

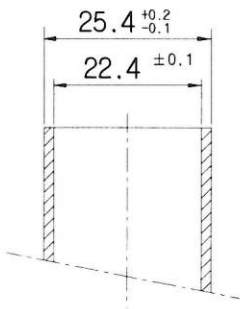

Detail Suction Tube

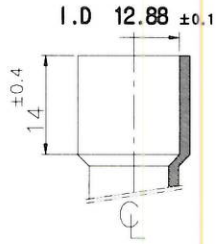

Detail Discharge Tube

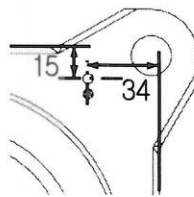

Detail Earth grounding

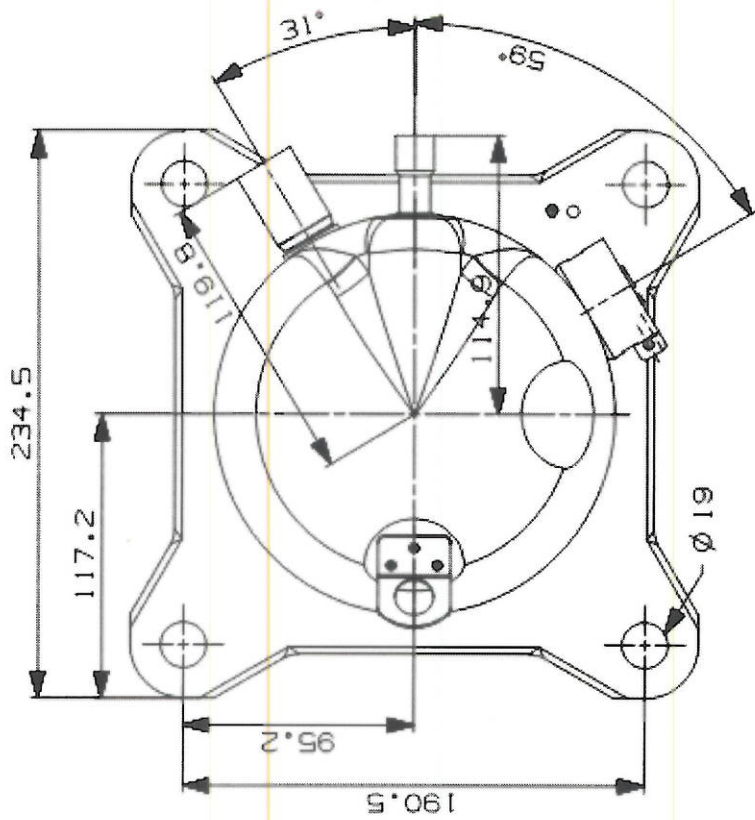
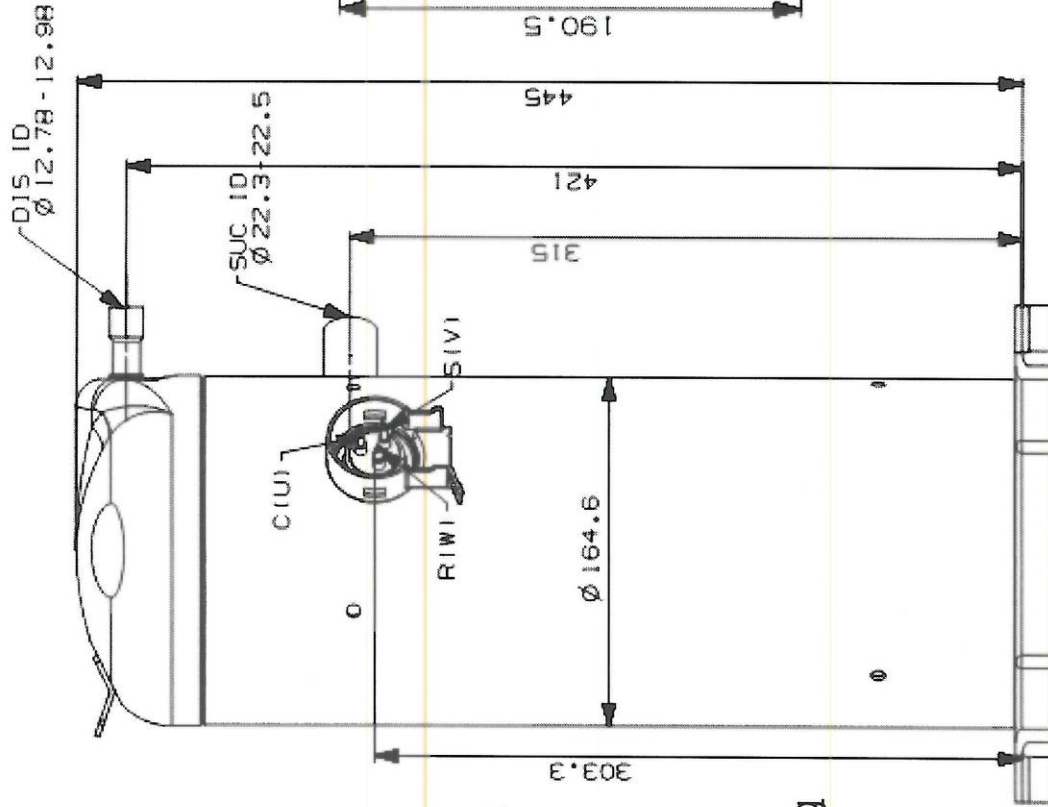

注释 (Remark) :

- 喷涂 PAINTING: 黑色(电泳涂装)
BLACK PAINT (ELECTRO DEPOSITION)
- 冷冻机油 OIL : POE or PVE 1360 ± 10cc.
- 干燥后充氮气 NITROGEN CHARGED AFTER DEHYDRATION

COMP. OUT LINE

UNIT	mm	SCALE	N / S
------	----	-------	-------

ABT061YTA

WIRING DIAGRAM

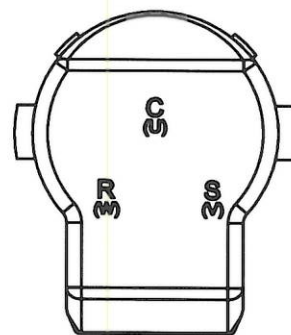

Cover Terminal

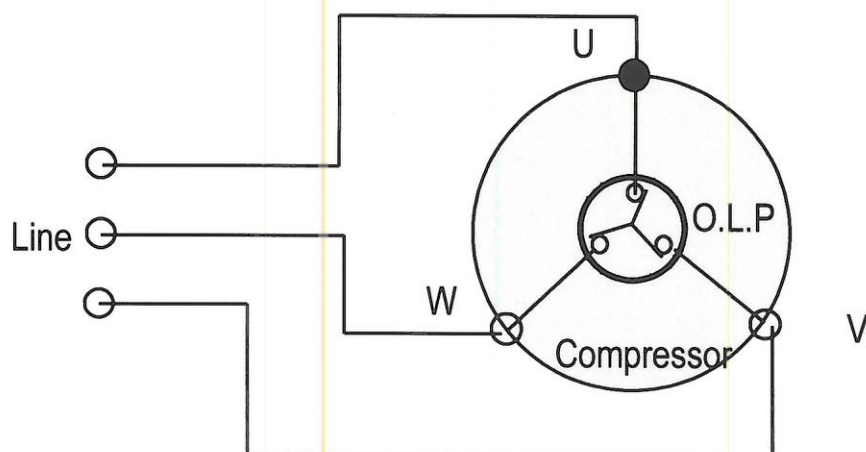

Accessory Fitting

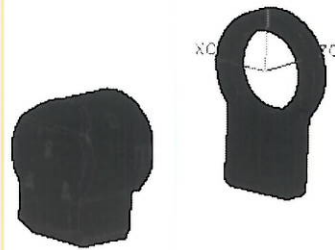
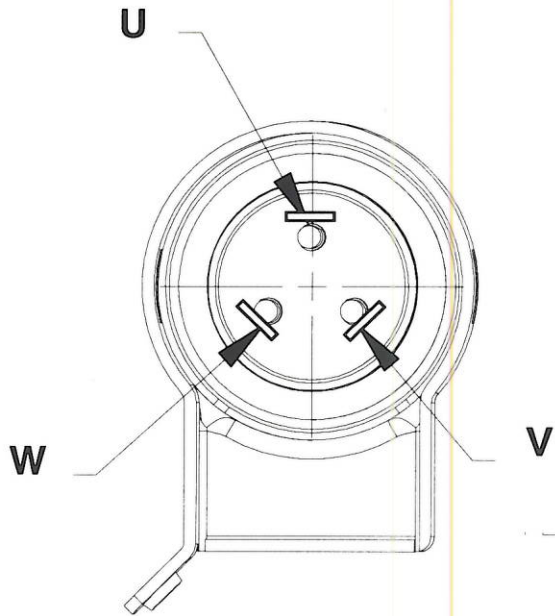

Earth Bolt



U,V,W Mark Embossed on Cover Terminal