

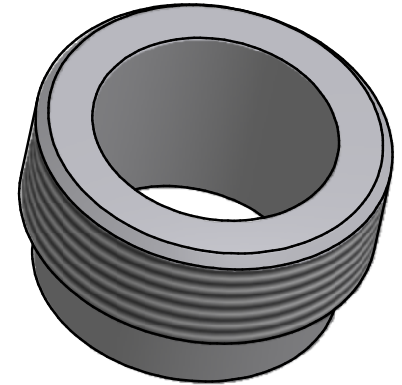

Rev No.	Alteration	Date	Checked	Approved
2	CHANGED DESIGN ACCORDING TO RD100699	2011/03/01	INRJ	PDM

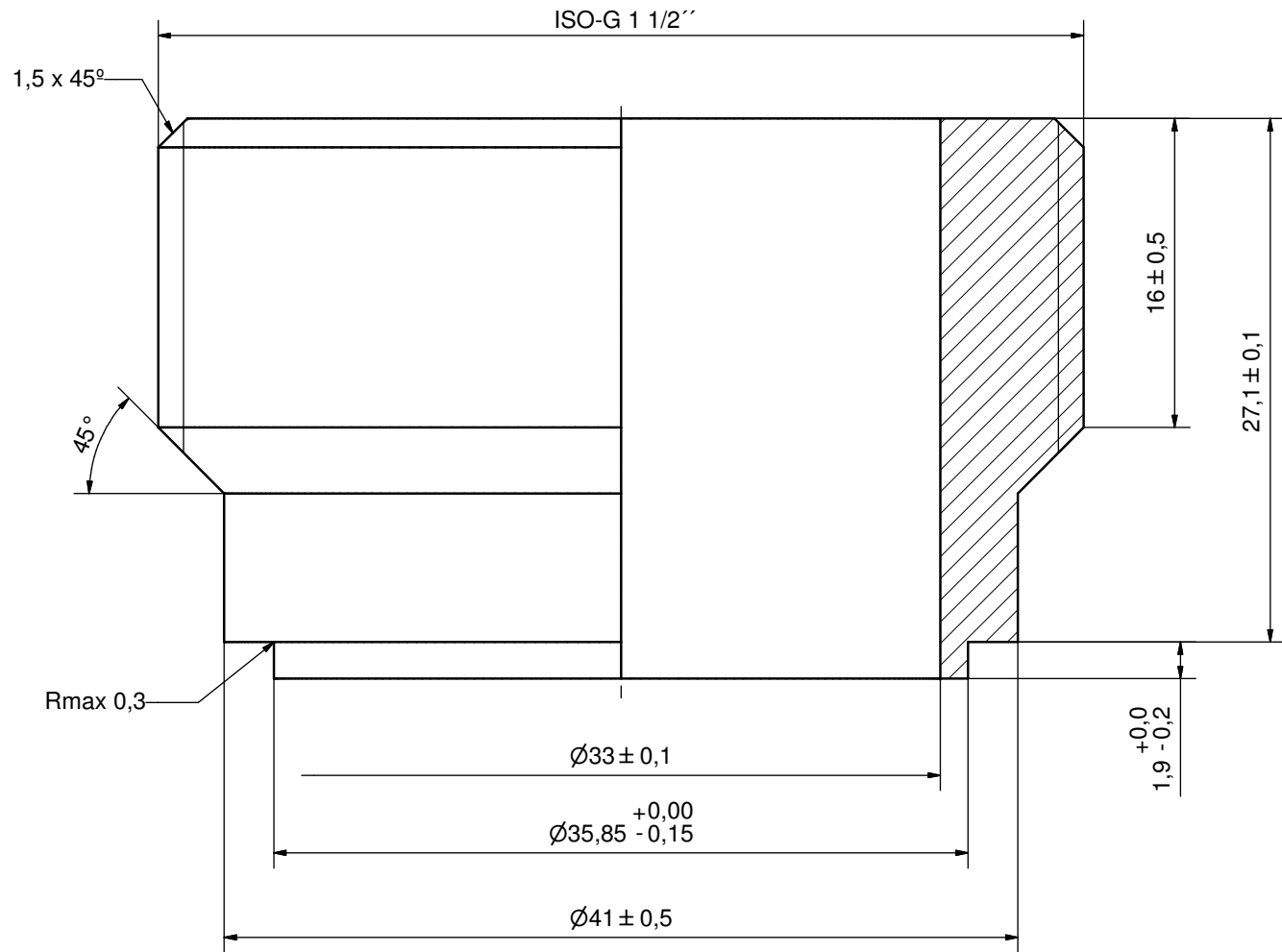

DEBURR SHARP EDGES; MAX 0.4

ACCORDING TO MQS  
MATERIAL

Drawn PB	Checked JA	Approved TOD	Created Date 2001-02-21	General geometrical tolerancing ISO 2768 m	General surface finish R <sub>a</sub> 3.2	Scale -
			Title <b>ISO-G 1 1/2</b>			
Article number -		DesignType	Drawing number CD000494	Revision 2	Sheet 1 (1)	