

殿

发行日期 DATE: _____

广东美芝全封闭型直流变频压缩机承认规格书

GMCC HERMETIC DC INVERTER COMPRESSOR SPECIFICATION

机种名(Model) : DA130M1C-31FZ

发行号(Issue NO.): GMCC-

承认印签

S I G N A T U R E

FOR REFERENCE

承认日期

D A T E

本规格书从贵公司承认之日起生效，一式两份。贵公司负责人承认签名之后请返回我公司一份，贵公司保留一份。

*This document will be effective with your authorized signature.
Please return one (1) copy of this form, and keep the other one (1) copies for your records.*

广东美芝制冷设备有限公司

广东省佛山市顺德区顺峰山工业开发区

GUANGDONG MEIZHI COMPRESSOR LIMITED

Shunfengshan Industrial Development Zone

Shunde Foshan City, Guangdong Province, P.R. CHINA

承 认	担 当

1. 规格 Specification

压缩机型号 Model Name		DA130M1C-31FZ
压缩机形式 Compressor Type		旋转式直流变频压缩机 ROTARY DC-INVERTER COMPRESSOR
安全认证 Safety Approval		CCC
额定频率范围 Rated frequency Range		18~110 S ⁻¹
总重量 Weight		(包括冷冻机油 Incl. Oil) 8.35 kg
使用冷媒 Refrigerant Type		R410A
压缩机 机构部	汽缸容量 Displacement	13.0 cm ³ /rev
	封入油量 Oil Charged	ESTER OIL VG74 480 ml
电机部	电机的形式 Motor Type	直流无刷电动机 (转速可变型) DC Brushless Motor (Revolution Variable)
	极数 Pole Numbers	4 极 4 Pole
	起动方式 Starting Type	直流专用变频器起动 DC Inverter Starting
	卷线阻抗 Coil Resistance	(20℃ 时) 1.77 Ω
	绝缘级别 Insulation Grade	E 级 E Grade
吐出管内径 ID. Of Discharge Pipe		8.1 mm
吸入管内径 ID. Of Suction Pipe		12.9 mm

2. 性能 Performance Parameters

☆ 冷冻能力 Capacity	3940±5%	W
☆ 输入功率(含变频器消耗功率) Input Power (Incl. Inverter)	1005±5%	W
☆ 电流 Current	3.80±5%	A
☆ COP	392±5%	%
★ 噪音 Noise (Sound Power Level)	70	dB(A) 以下 MAX
★ 振动 Vibration	5.5	m/s ² 以下 MAX
绝缘阻抗 Insulation Resistance	(封入氮气时 Nitrogen Charged) 20 MΩ 以上	
绝缘耐压 WITHSTAND VOLTAGE	AC1500V-1min	
残留水分量 Residual Moisture	冷凝法	150 mg 以下
含尘量 Residual Impurities		30 mg 以下

☆测定条件 RATING CONDITIONS

- 回转速度 REVOLUTION :60 S⁻¹
- 电源 POWER :广东美芝专用变频器
- 冷凝温度 COND. TEMP. :42.3℃
- 蒸发温度 EVAP. TEMP. :2.8℃
- 吸气温度 RETURN GAS TEMP. :12.8℃
- 过冷却液温 LIQUID TEMP. :34.3℃

★测定条件 RATING CONDITIONS

- 回转速度 REVOLUTION : 60 S⁻¹
- Pd/Ps=2.44/0.77MPa

※ 根据广东美芝量热标准 ACCORDING TO GMCC'S CALORIE-METER STANDARD

3. 配线接线图及电气部品规格

Wire Connection Figure & Electrical Parts Spec.

3-1、配线接线图 Wire Connection Figure

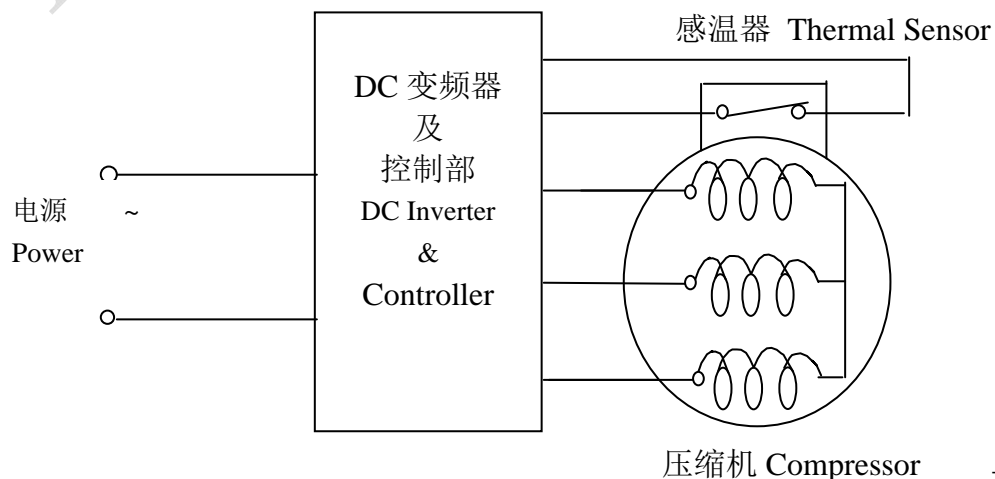

3-2. 电气部品 Electrical Parts

品名 Parts Name	规格 Specification
感温器 Thermal Sensor	-----

4. 使用条件（附纸参照使用压力条件范围）

Application Limitation (See the Attached Chart of Limitation of Operation Pressure)

项目 Item	标准条件 Standard Condition	过负荷条件 Overload Condition	12~18 S ⁻¹ 运转时
吐出压力 (MPa (G)) Discharge Pressure	3.28 以下 Max.	4.15 以下 Max.	高压-低压 Pd-Ps ≥ 0.2Mpa
吸入压力 (MPa (G)) Suction Pressure	0.53~0.98	0.23~1.15	
压缩比 Compressing Ratio	7.5 以下 Max	7.5 以下 Max	
电机卷线温度 (°C) Motor Coil Temp.	100 以下 Max	125 以下 Max	
吐出管温度 (°C) Discharge Temp.	100 以下 Max	115 以下 Max	
允许冷媒封入量 Max Refrigerant	(整个装置的最大封入量) R410A 1.6 kg 以下		
液体回流量 Liquid Feedback	无液体冷媒回流 No Liquid Refrigerant Return		
断续运转间隔 Intermittent Operation	30 S ⁻¹ 以上时: 每一循环 5 分钟以上 (ON 2 分钟以上, OFF 2 分钟以上) When over 30 S ⁻¹ : Longer Than 5 minutes for Each Cycle (On—Over 2Min. Off—Over 2Min.) 30 S ⁻¹ 以下时: 每一循环 8 分钟以上 (ON 5 分钟以上, OFF 2 分钟以上) When below 30 S ⁻¹ : Longer Than 8 minutes for Each Cycle (On—Over 5Min. Off—Over 2Min.)		
ΔT (壳底部温度-凝缩器中间温度) (Comp Bottom Temp. — Condensing Temp.)	连续运转时 (包括除霜、除湿) 5 K 以上 Continuous Running: ≥5K 控制运转时 (ON • OFF 时) 0 K 以上 Intermittent Running: ≥0K 室外温度低于 0°C 时, 推荐压缩机在 26 S ⁻¹ 以上的转速运行. When the Outdoor Temp. is Below 0°C, Compressor Should Be Operated at Revolution Over about 26 S ⁻¹ .		
压缩机实际运转数 Actual Revolution	18~120S ⁻¹ (但是, 始动时除外) (Excluding Starting Moment)		
冷媒沉积启动及除霜开始, 恢复时 When Refrigerant Soaking Starting, Defrost Starting & Resuming	在转速 60、90 S ⁻¹ 附近各保持运转 1 分钟以上。 Keep Running at about 60 and 90 S ⁻¹ for More Than 1 Minute.		
电机通电加热时 When Compressor Heated	请确保电机绕组温度为 55°C 以下。 Keep Motor Winding Temperature Below 55°C.		
启动时压力 Pressure at Starting	高压侧与低压侧保持平衡 Pressure Should Balanced Between High & Low Pressure Side		
冷媒沉积启动时 When Refrigerant Soaking	始动时不发出异音 No Strange Noise.		

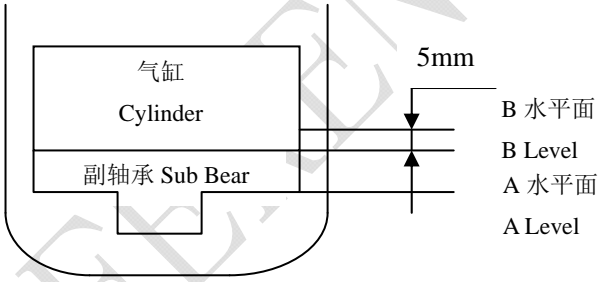
Starting	
推荐除霜转速 Recommended Defrost Revolution	除霜时 90 S^{-1} 以下 Less Than 90 S^{-1} When Defrosting
推荐转速变化速度 Recommended Freq. Variation Speed	1 S^{-1} (不会引起故障及油面下降的速度) 1 S^{-1} (The Speed Not Resulted in Damage or Oil Level Down)
允许倾斜角度 Gradient Angle	产品安装时 5° 以内 Less Than 5°
相间不平衡电压 Voltage Unbalance Among 3 Phases	2.25% 以内 Less Than 2.25%
油面水平确认: 超负荷、低负荷时; 冷媒沉积启动时; 除霜开始、恢复时; *超过最长配管时; *超过最大落差时; 等 Oil Level Confirmation Test At: Overload & Low load Running; Refrigerant Soaking Starting, Defrost Starting & Resuming; Connection Pipe over 15m; Elevation Over 5m; etc.	用带视窗的压缩机确认 运转安定时 (包括连续和断续运行), 在 B 水平线以上 始动 3 分钟以内, 在 A 水平线以上 Oil Level Confirmation Test Performed with Side Glass Compressor: At Steady Running (include Continuous or Intermittent Operation): Oil Level Should Be Higher Than B Line. Within 3 Minutes at starting: Oil Level Should Be Higher Than A Line. 

其他 Others

- 不要给吐出管、吸入管施加弯曲的力, 强制其弯曲。
而且, 对于始动、运转停止以及运输搬运等时所受冲击, 配管设计时, 各管许容应力如下: 始动、停止时= 29.4N/mm^2 以下, 运转时= 19.6N/mm^2 以下
Don't Provide Any Force on Discharge & Suction Pipes.
The Piping Stress Should Be Less Than 29.4N/mm^2 at Starting & Stopping, And Less Than 19.6N/mm^2 at Running When Designing the Piping.
- 压缩机不允许横置、倒置, 在搬运时不允许跌落。
Do Not Put a Compressor On Its Side OR Turn It Over. And Do Not Fall It Off When Moving.
- 绝对不允许空气中运转
COMPRESSING AIR IS NOT PERMITTED.
- 压缩机密封塞拔除后, 请尽快使用, 不要将压缩机长时间放置。
Please Assemble the Compressor in Your Air Conditioner Rapidly after Removing the Plugs.
Don't Place the Comp. In Air for a long time.
- 电气品要使用弊社所指定的规格同等品。
Please Use the Accessories Indicated By Our Company.
- 冷媒量超过规定量时, 需另行协商决定压缩机规格。(此时要考虑增加储液器、油加热器)
When the Amount of Refrigerant Charged in the Air Conditioner is Over the Max Amount Allowable, Compressor Specification Should Be Discussed. (Install Additional Accumulator, Oil Heater, etc.)
- 冷媒填充原则上从高压侧开始实行。
Refrigerant Must Always Be Filled From The Higher Side Of The Refrigeration Cycle.

- 8) 避免因误配线发生逆转。(若发生逆转, 则压缩机不能再使用)
Avoiding Compressor Running in Reverse Caused by Connecting Electrical Wire Incorrectly. (Don't Reuse the Compressor after Running in Reverse.)
- 9) 当旋转指令信号与转子位置检出信号不相匹配时, 会导致压缩机停止运转, 请注意。
When the Rotation Indication Signal is not Matched with the Rotor Position Checking Signal, the Compressor May Stop Running.
- 10) 绝对禁止将交流电直接印加在压缩机端子上, 否则会导致转子退磁。
Warning! In Case AC Voltage is Impressed to Compressor, the Compressor Performance Will Be Lower Because of its Rotor Magnetic Force Decreasing.
- 11) 如变频驱动电源的晶体管发生短路(特别是在高转速 $60 S^{-1}$ 以上时), 会导致转子退磁, 请注意。
Warning! In Case a Drive Transistor is Shorted in a High-Rotation (Over $60 S^{-1}$), the Compressor Performance Will Be Lower Because of its Rotor Magnetic Force Decreasing.
- 12) 请不要裸手触摸运行中或刚停机正处于高温的压缩机, 当心烫伤。
Do not touch the compressor with bare hands during operation or immediately after stoppage. The compressor is at a high temperature. There is the danger of burns.
- 13) 维修保养设备时必须配戴防护眼镜。由于焊枪温度过高, 拆卸配管时, 当心会有冷媒、油的溅出而导致烫伤或进入眼中。
Wear safety goggles when servicing the unit. When removing the tubes by heating it with a burner, there is the danger of burns or eye injury if the refrigerant and/or oil remaining in the tubes is emitted.

5. 图纸/附件清单 (见附页)

Drawing/Accessories List (See the Attached Pages)

名 称	Parts Name	数量 (Pieces)	图 号 (Drawing No.)	备注
外形图	DRAW EXTER	1	1K518845Gr	
端子盖	TERMINAL COVER	1	1K14722211	
端子螺母	TERMINAL NUT	1	1K14723810	
端子垫片	TERMINAL PACKING	1	1K14300711	
橡胶垫	RUBBER CUSHION	3	1K14910610	
接地螺钉	EARTHING HEX BOLT	1	1K14300210	
接地螺钉垫片	WASHER FOR EARTHING BOLT	1	1K14300310	

*!请注意 !Attention:

如使用压缩机底脚上的接地孔, 务必将原压缩机上的防锈保护钢质螺钉与垫片卸下废弃, 换上附件中的铜质螺钉与垫片或相当品。

If the Earthing Hole on the Base of Compressor will have been connected with Earthing Wire, Please Remove and throw away the Antirust Steel Bolt and Washer which has been installed on Compressor, and Use the Copper Bolt and Washer listed above or Equivalent.

DA130M1C-31FZ压缩机使用条件范围 Operation Limitation of Model «压缩机型号»

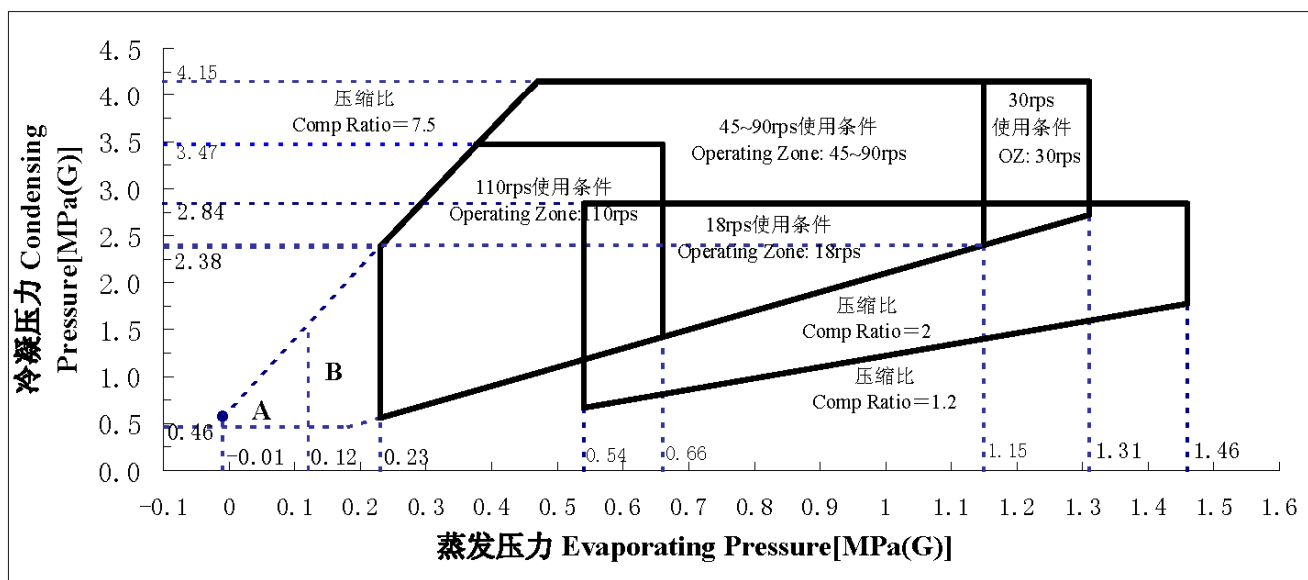
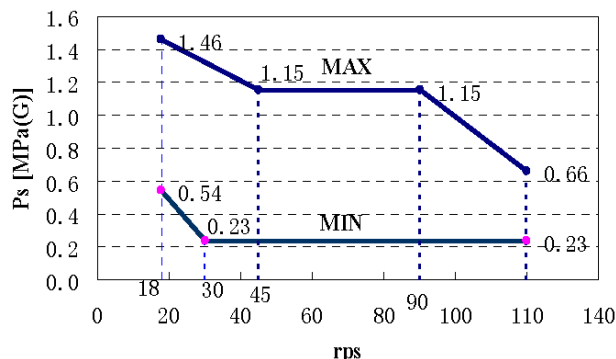
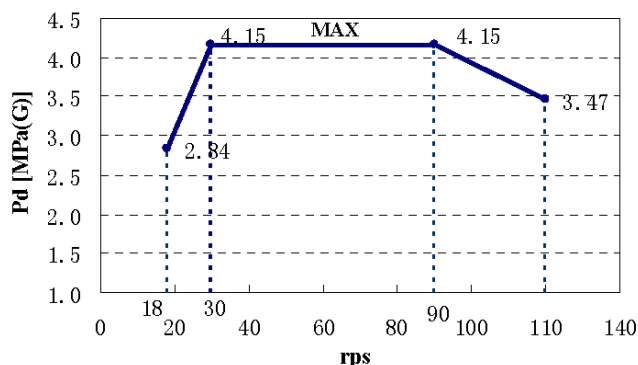

备注 Note:

- A区域: 冷媒沉积启动时, 5分钟内可使用。
A Zone: For 5 min, after starting at soaking out.
- B区域: 除霜及复位再启动时, 3分钟内可使用。
B Zone: For 3 min, defrosting & re-starting.
- 18rps使用条件: 控制运转时, 最短运转时间必须在10分钟以上。油面必须确保在B水平面上。
Operating Limitation at 18rps: the Minimum Running Time should Be More Than 10min at Controlled Intermittent Operation. The Oil Level Should Be Higher Than B Level.

低速时Min压缩比 (Min Compressing Ratio at Low Rotation)

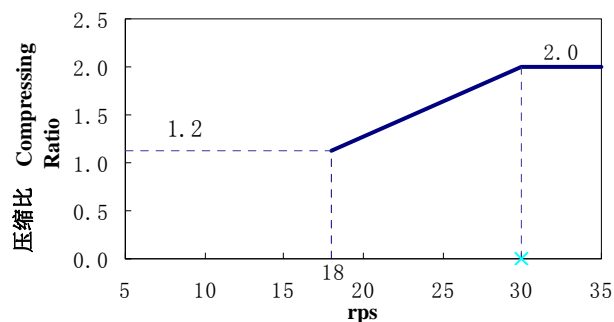

ELE COMPONENTS

Drawing No. 1K14722114

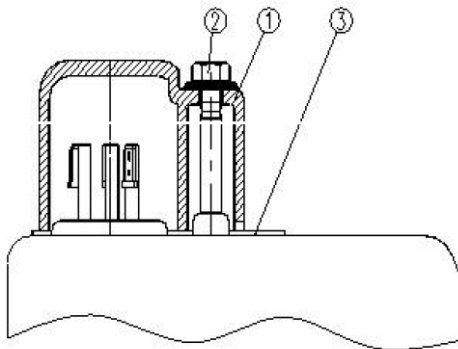
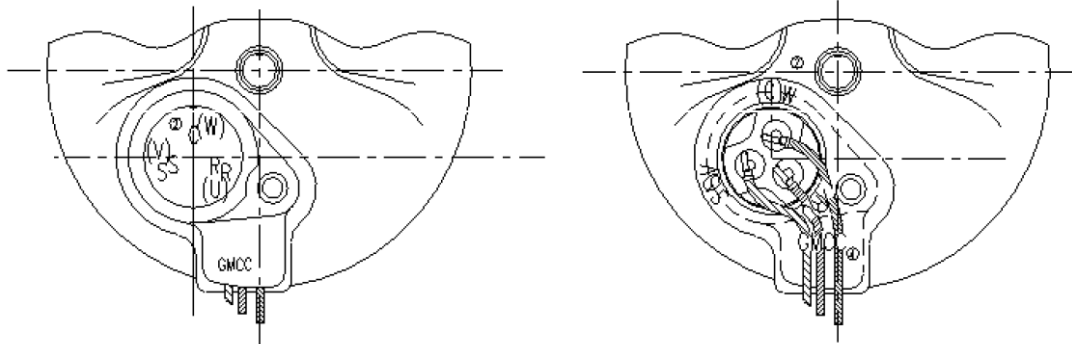

③	TERMINAL PACKING	1K14723810
②	TERMINAL NUT	1K14300711
①	TERMINAL COVER	1K14722211
PART NO	TITLE	DRAWN NO

NOTES

Tightening torque of terminal nut: $1.2 \pm 0.2 \text{ Nm}$

TERMINAL COVER

Drawing No.1K14722211

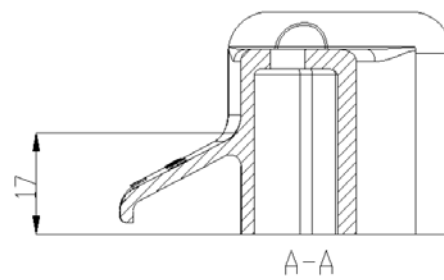
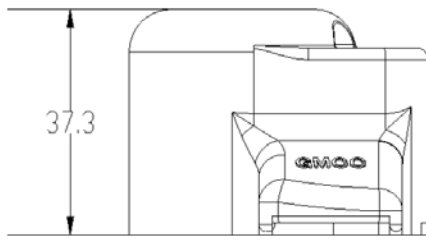
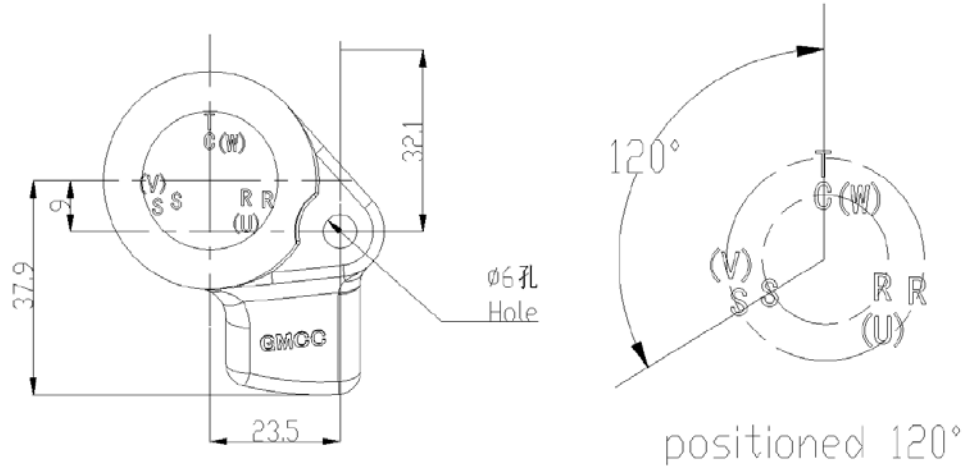

NOTES

MATERIAL: MATERIAL: POLYCARBONATE or POLYBUTYLENE TEREPHTHALATE
or BULK MOLDING COMPOUND
COLOR: BLACK

TERMI PACKING

Drawing No.1K14723810

THICKNESS 1.2mm

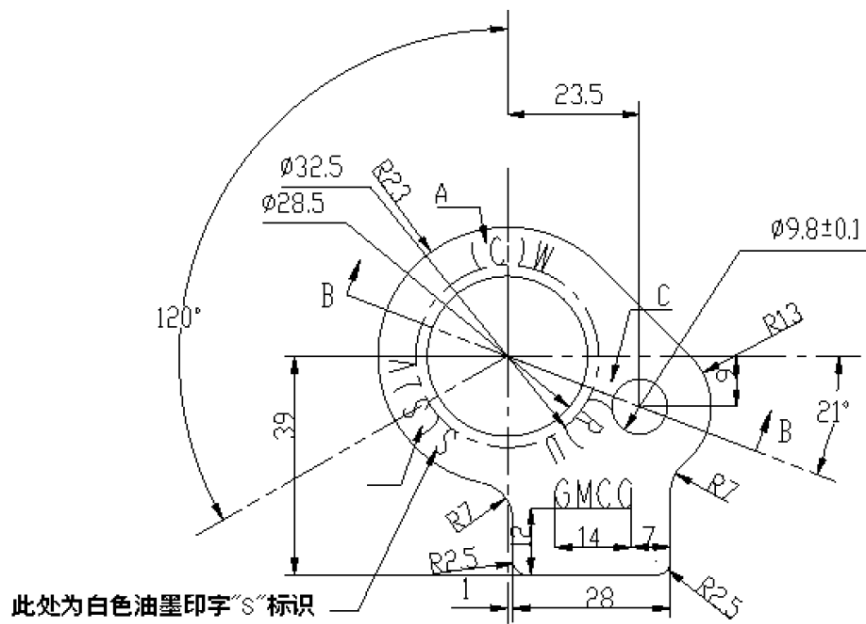

NOTES
 MATERIAL:SI
 COLOR:BLACK

TERMINAL NUT

Drawing No. 1K14300711

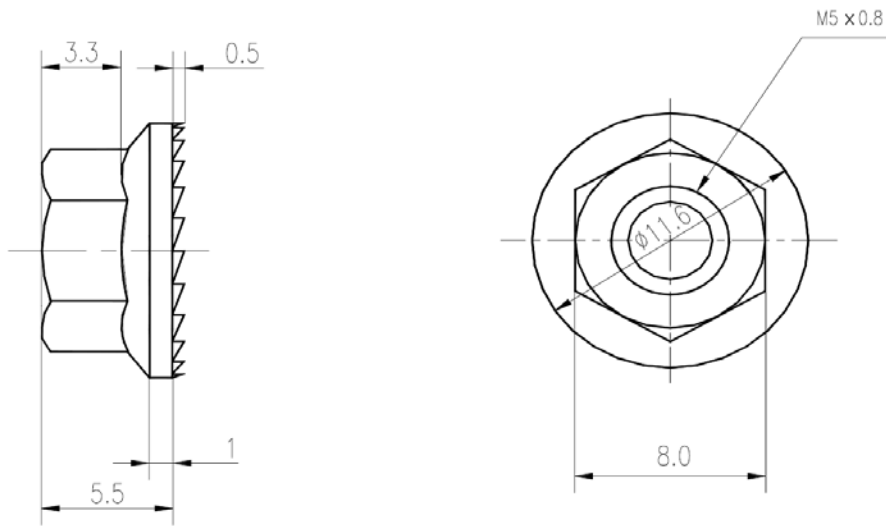

NOTES

MATERIAL: SWCH12A

TREATMENT: WITHOUT HEXAVALENT CHROMIUM COMPOUNDS (Ep-Fe/Zn 2-CM 2镀锌处理)

FC

RUBBER CUSHION

Drawing No. 1K14910610

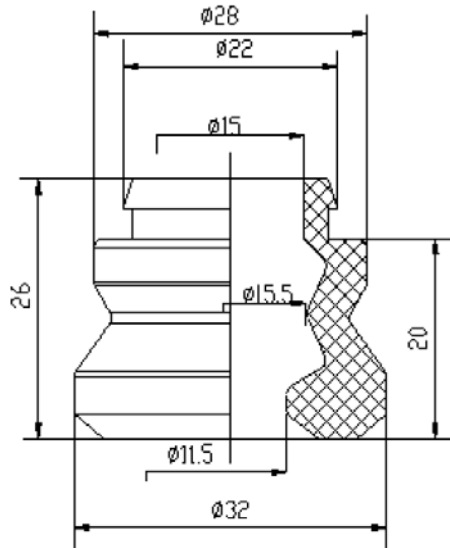

NOTES
MATERIAL:EPDM
HARDNESS: HS=39+5

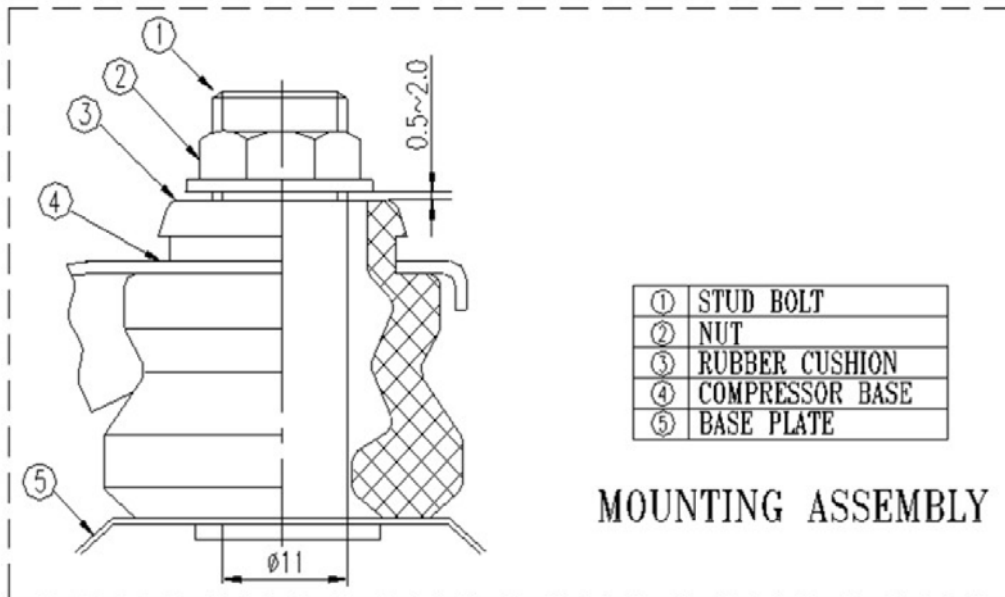

MOUNTING ASSEMBLY

EARTHING HEX BOLT

Drawing No. 1K14300210

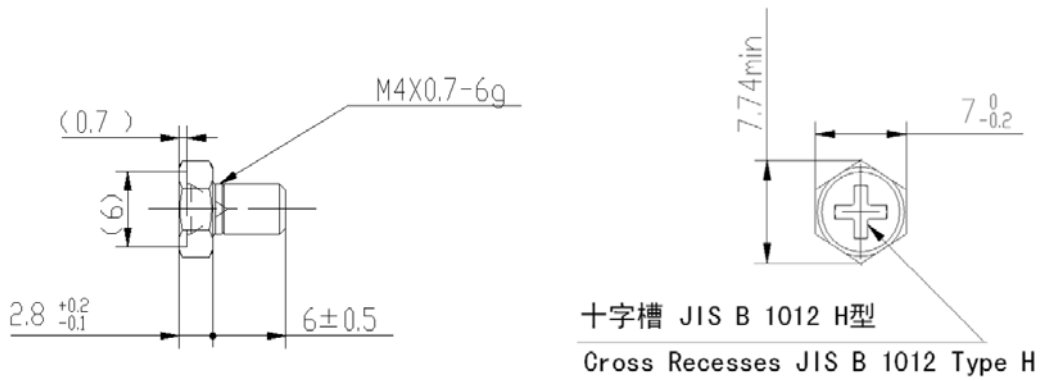

NOTES

MATERIAL: C2700W-1/4H

TREATMENT: ELECTROPLATED COATINGS OF NICKEL (Ep-Cu/Ni 3 b)

WASHER FOR EARTHING BOLT

Drawing No. 1K14300310

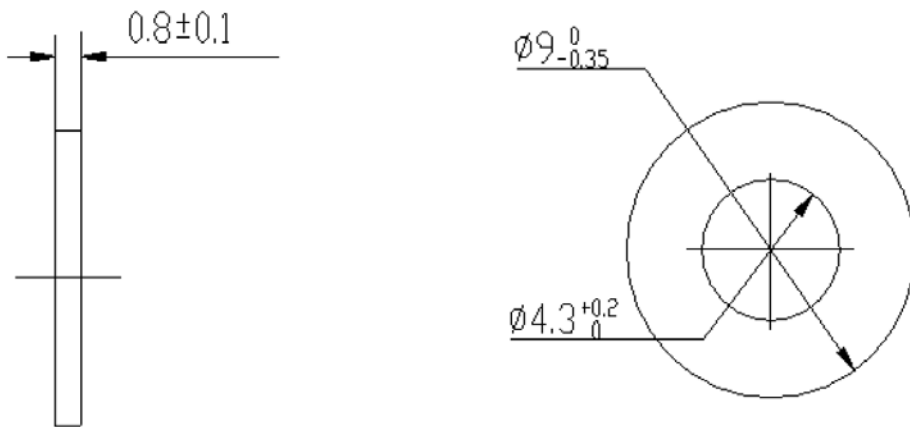

NOTES

MATERIAL: C2801P

TREATMENT: ELECTROPLATED COATINGS OF NICKEL (Ep-Cu/Ni 3 b)

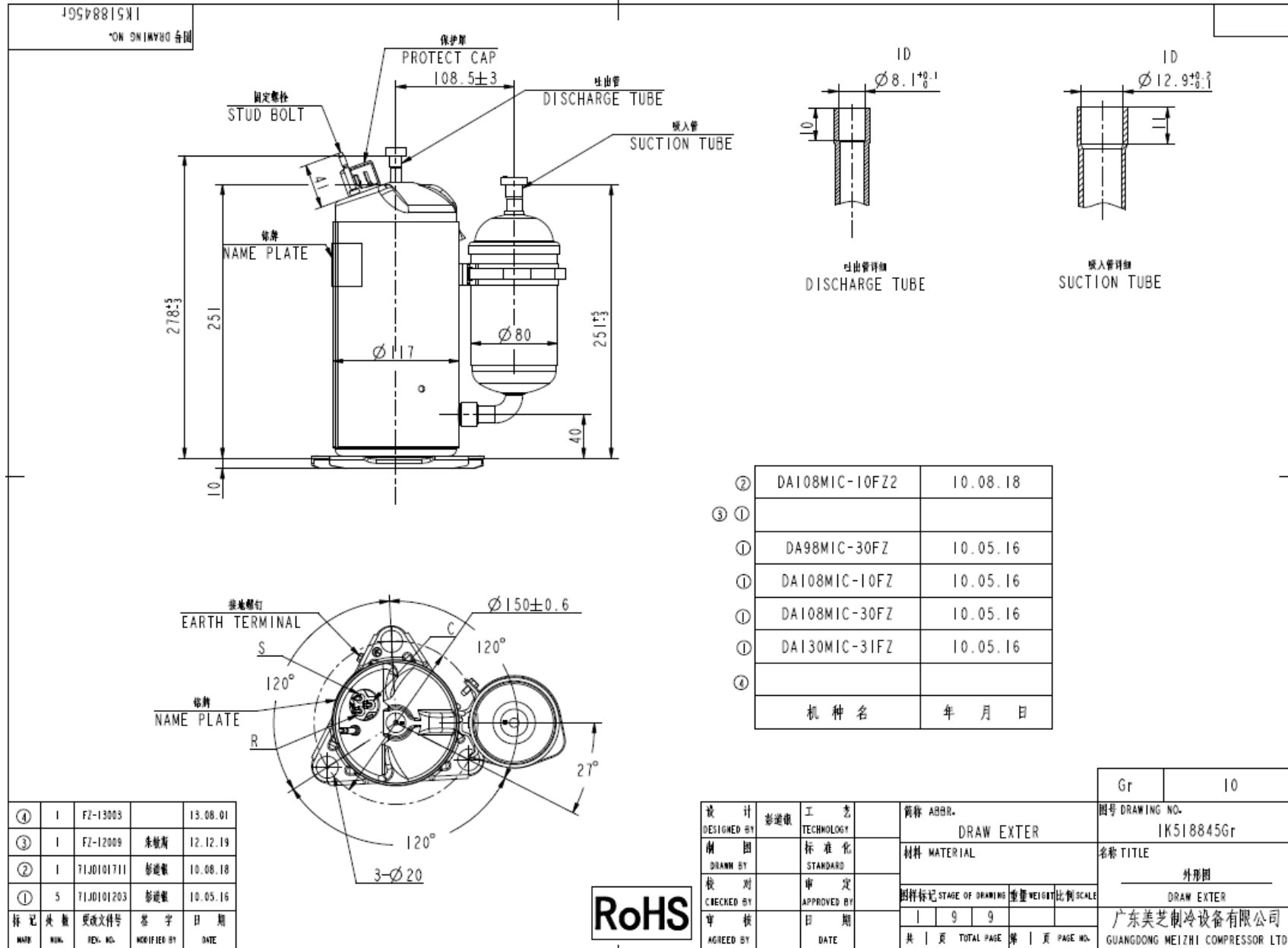

②	DA108MIC-10FZ2	10.08.18
③		
①	DA98MIC-30FZ	10.05.16
①	DA108MIC-10FZ	10.05.16
①	DA108MIC-30FZ	10.05.16
①	DA130MIC-31FZ	10.05.16
④		
	机种名	年月日

④	1	FZ-13003		13.08.01
③	1	FZ-12009	朱敏斯	12.12.19
②	1	71J0101711	彭进敏	10.08.18
①	5	71J0101203	彭进敏	10.05.16
标记	共	更改文件号	签字	日期
MARK	NUM.	REV. NO.	MODIFIER BY	DATE

Gr	10
图号 DRAWING NO.	IK518845Gr
名称 TITLE	外形图
DRAW EXTER	
图样标记 STAGE OF DRAWING	重量 WEIGHT
比例 SCALE	
广东美芝制冷设备有限公司	
GUANGDONG MEIZHI COMPRESSOR LTD	

设计 DESIGNED BY	彭进敏	工艺 TECHNOLOGY		简称 ABBR.	DRAW EXTER
制图 DRAWN BY		标准化 STANDARD		材料 MATERIAL	
校对 CHECKED BY		审定 APPROVED BY		图样标记 STAGE OF DRAWING	重量 WEIGHT
审核 AGREED BY		日期 DATE		比例 SCALE	
				1	9
				共	页 TOTAL PAGE
				第	页 PAGE NO.

RoHS

附：DA130M1C-31FZ电机参数列表

Accessories: DA130M1C-31FZ Motor Parameter Sheet

No.	項目 Item	参数 Parameter	备注 Remark
1	压缩机型号 Compressor Model	DA130M1C-31FZ	
2	转子极数 Rotor Pole	4 极/Poles	
3	运行频率范围 Rated Frequency Range	18~110 rps	
4	磁石材料 Magnet Material	稀土类 NdFeB	
5	永磁体减磁电流峰值 Demagnetizing Current	25 Apk	130℃下, -5%减磁率 at 130℃, -5% Demagnetizing Rate
6	d 轴电感 (相间) Inductance-Ld (per phase)	16.1 mH	额定电流下 Under Rated Current
7	q 轴电感 (相间) Inductance-Lq (per phase)	22.1 mH	额定电流下 Under Rated Current
8	定子线圈电阻 Winding Resistance	1.77 Ω	线间电阻 (20℃下) line-to-line (at 20℃)
9	感应电压常数 Voltage Constant	42.4 Vrms/Krpm	线间电压 line-to-line
10	电机转矩常数 Torque Constant	0.635 N·m/Arms	
11	转动惯量 Inertia	2.63×10^{-4} Kg·m ²	
12	磁通量 Φa Flux Φa	0.578~0.631 Wb	