



Digital Capacity Control for Copeland Scroll™ Refrigeration Compressors





TABLE OF CONTENTS

<u>Section</u>	<u>Page</u>	<u>Section</u>	<u>Page</u>
Safety		Figures and Tables	
Safety Instructions .....	2	Digital Solenoid Valve and Coil Kits .....	7
Safety Icon Explanation .....	2	Example of Digital Compressor Selection .....	7
Instructions Pertaining to Risk of Electrical Shock, Fire, or Injury to Persons .....	3	Operating Envelopes .....	8
Safety Statements .....	3	20 Second Operating Cycle .....	8
Introduction		Injection Assembly Diagram with Sweat Connections .....	9
Theory of Operation .....	4	Injection Assembly Diagram with Rotalock Connections .....	10
Nomenclature .....	4	Unloaded Operation Solenoid Valve Energized (Open) .....	11
Digital Performance .....	4	Loaded Operation Solenoid Valve De-Energized (Closed) .....	11
Operating Envelopes .....	4	Typical Modulated Power Reduction .....	12
Restricted Operating Envelope .....	4		
7.5 to 15 HP Digital Scroll Restrictions .....	4		
Control .....	5		
Recommended Application Settings .....	5		
Control Requirements With Control Module .....	5		
Control Requirements Without Control Module .....	5		
Inputs .....	5		
Outputs .....	5		
Oil Management .....	5		
Solenoid Valve .....	5		
Solenoid Valve Mounting .....	6		
Thermistor .....	6		
Discharge Line Check Valve .....	6		
Multiple Compressor Application .....	6		
Scroll Reference Material .....	6		





Safety Instructions

Copeland Scroll™ compressors are manufactured according to the latest U.S. and European Safety Standards. Particular emphasis has been placed on the user's safety. Safety icons are explained below and safety instructions applicable to the products in this bulletin are grouped on page 3. These instructions should be retained throughout the lifetime of the compressor. You are strongly advised to follow these safety instructions.

Safety Icon Explanation

	DANGER indicates a hazardous situation which, if not avoided, will result in death or serious injury.
	WARNING indicates a hazardous situation which, if not avoided, could result in death or serious injury.
	CAUTION, used with the safety alert symbol, indicates a hazardous situation which, if not avoided, could result in minor or moderate injury.
	NOTICE is used to address practices not related to personal injury.
	CAUTION, without the safety alert symbol, is used to address practices not related to personal injury.

Instructions Pertaining to Risk of Electrical Shock, Fire, or Injury to Persons

 <b>WARNING</b>	<p><b>ELECTRICAL SHOCK HAZARD</b></p> <ul style="list-style-type: none"> <li>• Disconnect and lock out power before servicing.</li> <li>• Discharge all capacitors before servicing.</li> <li>• Use compressor with grounded system only.</li> <li>• Molded electrical plug must be used when required.</li> <li>• Refer to original equipment wiring diagrams.</li> <li>• <b>Electrical connections must be made by qualified electrical personnel.</b></li> <li>• Failure to follow these warnings could result in serious personal injury.</li> </ul>
 <b>WARNING</b>	<p><b>PRESSURIZED SYSTEM HAZARD</b></p> <ul style="list-style-type: none"> <li>• System contains refrigerant and oil under pressure.</li> <li>• Remove refrigerant from both the high and low compressor side before removing compressor.</li> <li>• <b>Use appropriate back up wrenches on rotalock fittings when servicing.</b></li> <li>• Never install a system and leave it unattended when it has no charge, a holding charge, or with the service valves closed without electrically locking out the system.</li> <li>• Use only approved refrigerants and refrigeration oils.</li> <li>• Personal safety equipment must be used.</li> <li>• Failure to follow these warnings could result in serious personal injury.</li> </ul>
 <b>WARNING</b>	<p><b>BURN HAZARD</b></p> <ul style="list-style-type: none"> <li>• Do not touch the compressor until it has cooled down.</li> <li>• Ensure that materials and wiring do not touch high temperature areas of the compressor.</li> <li>• Use caution when brazing system components.</li> <li>• Personal safety equipment must be used.</li> <li>• Failure to follow these warnings could result in serious personal injury or property damage.</li> </ul>
 <b>CAUTION</b>	<p><b>COMPRESSOR HANDLING</b></p> <ul style="list-style-type: none"> <li>• Use the appropriate lifting devices to move compressors.</li> <li>• Personal safety equipment must be used.</li> <li>• Failure to follow these warnings could result in personal injury or property damage.</li> </ul>

Safety Statements

- Refrigerant compressors must be employed only for their intended use.
- **Only qualified and authorized HVAC or refrigeration personnel are permitted to install, commission and maintain this equipment.**
- **Electrical connections must be made by qualified electrical personnel.**
- All valid standards and codes for installing, servicing, and maintaining electrical and refrigeration equipment must be observed.

## Introduction

On refrigeration applications where the load may vary over a wide range, some means of capacity control is often desirable for optimum system performance and control. In addition, compressor capacity modulation can reduce power and energy consumption, provide better dehumidification, reduce compressor cycling, and decrease the starting electrical load.

In order to achieve the above objectives, Emerson Climate Technologies has developed the Copeland Scroll Digital™ compressors, a unique and highly efficient method for modulating scroll compressors.

Digital technology will permit efficient modulation of Copeland Scroll™ compressors for high, medium, and low temperature applications. Digital technology assures smooth, vibration free operation by axially unloading the compliant scrolls.

## Theory of Operation

Digital capacity control is achieved by axially separating the scroll members. During the time the members are separated, there is no gas compression and approximately 10% power usage. By varying the amount of time the members are separated, capacity control between 10 and 100% can be achieved. The separation is achieved by bypassing a controlled amount of discharge gas to the suction side through a solenoid valve. The lowering of the pressure in the modulating chamber allows the scrolls to separate and as a result no pumping action takes place. The position of the scroll elements during the loaded and unloaded modes of operation are shown in Figures 6 and 7 at the end of this bulletin.

## Nomenclature

The Copeland Scroll Digital compressor model numbers are designated by a D in the third character, ZBD30KCE-TFD. Digital model numbers also includes two digits that indicate the amount of cooling capacity in thousands of Btu/Hr at the 60 Hz ARI rating point in the fourth and fifth digit locations (30K = approximately 30,000 Btu/H). For actual compressor performance information please visit “Detailed Product Information” at [emersonclimate.com](http://emersonclimate.com). Please refer to the product literature for model number details.

The low temperature digital models also offer economizer operation. This is designated by a V after the K in the model number ZFD18KVE-TFD. The requirements for economizer operation are covered in AE4-1327.

## Digital Performance

The power requirements vary as the load varies. The power required as a percent of load is shown in Figure 8.

For additional information on this product, please refer to the “Detailed Product Information” at [emersonclimate.com](http://emersonclimate.com).

## Operating Envelopes

The operating envelopes for Copeland Scroll Digital compressors are very similar to standard scroll compressor envelopes. (See Figures 1 and 2 at the end of this bulletin.) However, a 75psi (5.1bar) differential between discharge and suction must be maintained. Therefore, the lower right corner of the digital envelope is somewhat restricted.

### Restricted Operating Envelope

The published operating envelopes for the Digital compressors must be strictly followed. Please note in Figure 1, the dotted line on the lower right portion of envelope. The Copeland Scroll Digital compressor will not operate properly below the dotted line. The minimum differential pressure required across the piston is 75 psi (5.1bar). If this is not achieved, then measures such as raising the minimum condensing pressure may have to be considered to increase the differential.

\*Note that when running an extended unload cycle time at or near the lower right hand corner of the envelope that the condition will actually go beyond the dotted line during the off cycle as the suction pressure rises and the discharge pressure drops

### 7.5 to 15 HP Digital Scroll Restrictions

When operating the 7.5 to 15 HP digital scroll compressors (ZBD\*\*KC, ZRD\*\*KC, ZPD\*\*KC) with R-410A or R-407C in a refrigeration application (i.e. air dryer/ process chillers), Emerson recommends limiting the Digital Unloading at 30% to provide adequate motor cooling within the entire operating envelope of the compressors listed. 20% and even 10% digital loads can be maintained on all models if adequate return gas volume and temperature are available to provide adequate motor cooling to the compressor to prevent nuisance trips on the motors thermal protection circuit. System testing may be required to determine the digital limitation in various applications.

Note: The 7.5 hp ZBD57 is not restricted.

## Control

Capacity modulation is achieved by energizing and de-energizing the solenoid valve. When the solenoid valve is de-energized, the compressor capacity is 100%. When the solenoid valve is energized, the compressor capacity is zero. Therefore, the capacity achieved is the time average capacity, which is a variable from 10 - 100%. Example: If you have a 20-second cycle and the solenoid is de-energized for 16-seconds, and then energized for 4-seconds, the resulting capacity will be 80%, see Figure 3.

**Caution:** To minimize valve cycling and maximize system responsiveness, cycle times between 10 and 30 seconds should be used. Cycle time is defined as energized plus de-energized time. The minimum de-energized (loaded) time is 10% of the cycle time. This is required to provide gas flow for motor cooling. There is no maximum de-energized time.

**Recommended Application Settings for the Modulation on Copeland Scroll Digital™ Compressors** The pulse width modulation cycle time recommended is 20 seconds; for other values, check with your Application Engineer.

The minimum load and unload times will be limited to 2 seconds. These described load and unload times will give the compressor an operating range during a 20 second cycle from 10% load up to 90% load. The compressor can also operate at a 100% load for the full modulation sequence. The 2 seconds minimum times will give the unloader piston assembly time to both load and unload the scroll sets fully. If the load reduces past the 10% load the compressor motor should be shut down. Restarting of the compressor will be governed by the capacity rising above the 10% or more based on a modulation time of 20 seconds, and by the motor starting logic.

The system design should follow the required and recommended guidelines as detailed in the various Application Engineering Bulletins, which can be found on the website at [emersonclimate.com](http://emersonclimate.com). The compressor motor will only be restarted after an appropriate time delay. The time delay will begin at the most recent moment that the motor has stopped. The amount of delay will not be adjustable. The motor will have a start delay of 2 minutes. This will prevent a short cycling effect of more than 30 starts per hour.

## Start up and Shut Down

To improve the starting characteristics of the scroll compressor, the Copeland™ Digital Compressor

Controller (see AE8-1328) delays loading the compressor for .1 seconds at start up. Likewise, to eliminate the reverse rotation sound at shut down the compressor is unloaded 0.5 seconds before shut down. This should be taken into consideration when implementing a digital control sequence that does not include the Copeland Digital Compressor Controller.

**Control Requirements With Control Module** Refer to AE8-1328 for the digital control module that can be used with this compressor.

## Control Requirements Without Control Module

In order to control the digital modulation, two inputs and one output are required.

### Inputs

1. A discharge temperature thermistor is required on all compressors. The cut out temperature is to be set at 280°F (138°C).
2. Control can be done by any normal control parameter (i.e. suction pressure, air temperature, humidity, etc.)

### Outputs

There must be a 15 watt output to the solenoid valve at the appropriate chosen solenoid voltage.

## Oil Management

In a Copeland Scroll Digital™ compressor, oil leaves the compressor only during the “loaded” state when compression is taking place. During this “loaded” state, since the compressor is operating at full capacity, the gas and oil flow velocities are the same for a digital and fixed capacity compressor. Hence, no special oil management requirements exist for a Copeland Scroll Digital compressor. Using a 20lb check valve to deliver low pressure oil back to the digital compressor is not recommended. During digital operation with long unloaded cycles, the pressure in the crankcase will rise and the 20lb pressure differential for oil feed may not feed adequate oil. A high pressure oil feed is recommended for Copeland Scroll Digital compressors. Of course, when the compressor is in an “unloaded” state, no refrigerant or oil is passed through. The oil therefore travels through the system in a “pulsing” mode and returns to the compressor.

Refer to AE17-1320 for additional details on oil management with multiple compressor applications.

## Solenoid Valve

Due to the high life cycle requirements in a hot gas

environment, a special valve has been developed. A screen is provided in the digital solenoid valve to prevent debris from damaging valve operation.

Due to reliability requirements, only Emerson approved solenoid valves may be used for this application. All compressor warranties are null and void if the Emerson approved valve is not used.

For valve kit part numbers refer to Online Product Information at [emersonclimate.com](http://emersonclimate.com).

#### Solenoid Valve Mounting

While mounting the solenoid valve on the compressor, there are several different ways to support the weight of the valve coil to assist in eliminating the vibrations and resonance frequencies which might cause premature tubing fractures. See Table 1 for solenoid valve mounting kits available through Emerson Climate Technologies, Inc.

Some recommendations to use when installing the valve are as follows;

1. The valve operation is directional.
2. Solenoid valve must be mounted within 15° of vertical. Horizontal mounting is not permitted.
3. Mount the solenoid valve to the suction line. The tube from the solenoid to the suction should be as short as possible, less than 3" (76mm).
4. Mount the solenoid valve as close as possible to the compressor.
5. Do not restrict the inlet or outlet line size of the solenoid. Use 3/8" (9.5mm) soft drawn copper.
6. From the top cap to the solenoid a series of bends and or shock loops are required to dampen vibrations and resonance frequencies the assemblies might see during operation and start up. See Figures 4 and 5.
7. Solenoid tubing mounting kits, including solenoid valves are available from Emerson Climate Technologies, Inc.

#### Thermistor

The discharge thermistor must be connected to the Copeland™ Digital Compressor Controller, see AE8-1328. The thermistor kit number is 998-0166-00.

#### Discharge Line Check Valve

In multiple compressor applications an external check valve is required in the discharge line of the Digital compressor. A recommended check valve is:

Manufacturer: Emerson Flow Controls  
Description: ACK-8  
Part No.: 064987

#### Multiple Compressor Application

To ensure smooth and continuous modulation, selection of the digital and nondigital compressor capacities can be made according to the following rule.

Rule: for optimum suction pressure control, the following guideline is recommended in the selection of digital scroll and fixed compressors, per suction header:

- $D > F1$
- $F2 < D + F1$
- $F3 < D + F1 + F2$
- .....
- $FN < D + F1 + F2 + \dots + FN-1$

In the above equations,

D is digital scroll capacity or horse power  
F1, ...FN are fixed speed compressor capacity or horse power

Digital is recommended to be the lead compressor

See Table 2 for a selection example by Btu/hr.

#### Scroll Reference Material

For general scroll compressor guidelines, refer to the following Application Engineering Bulletins:

- AE4-1317 ZBKC/ZBKCE Refrigeration Scroll
- AE4-1318 ZBKC/ZBKCE Refrigeration Scroll 7-15HP
- AE17-1320 Oil Management in Scroll Compressors in Parallel Applications
- AE4-1327 Economized Vapor Injection (EVI) Compressors

Table 1  
Digital Solenoid Valve and Coil Kits

Kit Number	Identification	Details
998-0073-00	Tubing kit with solenoid	Sweat
998-0066-00	Tubing kit with solenoid / ZBD30, ZBD45,ZBD57, ZFD13, ZFD18, ZFD25	Rotalock
998-0066-09	Tubing kit with solenoid / ZBD21, ZBD29	Rotalock
923-0058-08	Solenoid coil	110 volts
923-0058-09	Solenoid coil	220 volts
923-0058-00	Solenoid coil	24 volts

Table 2  
Example of Digital Compressor Selection

	Cooling Demand	Digital	Fixed	Fixed	Fixed	Fixed	System Output
		ZBD45	ZB30	ZB30	ZB30	ZB30	
	Capacity @ +10/120	3630 to 36300	24100	24100	24100	24100	
Load	0	OFF	OFF	OFF	OFF	OFF	0
Load	3,630 to 36,300	ON	OFF	OFF	OFF	OFF	3,630 to 36,300
Load	36,301 to 60,400	ON	ON	OFF	OFF	OFF	36,301 to 60,400
Load	60,401 to 84,500	ON	ON	ON	OFF	OFF	60,401 to 84,500
Load	84,501 to 108,600	ON	ON	ON	ON	OFF	84,501 to 108,600
Load	108,601 to 132,700	ON	ON	ON	ON	ON	108,601 to 132,700

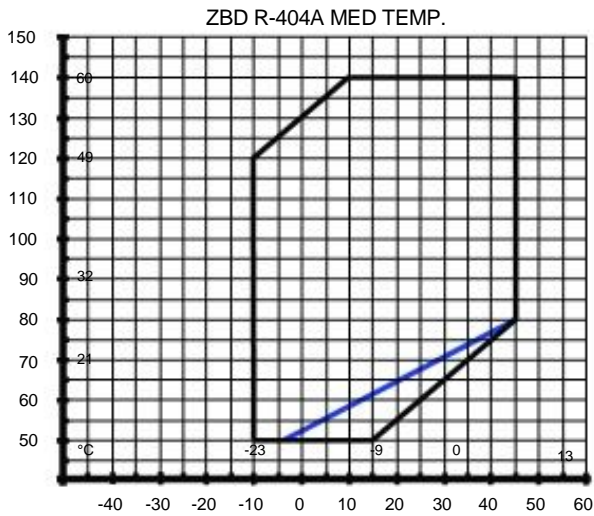

Figure 1  
ZBD R-404A Medium Temp.

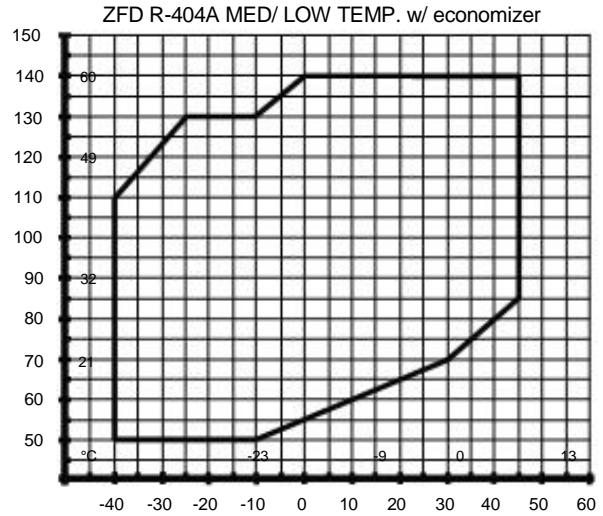

Figure 2  
ZFD R-404A Med/Low Temp. w/Economizer

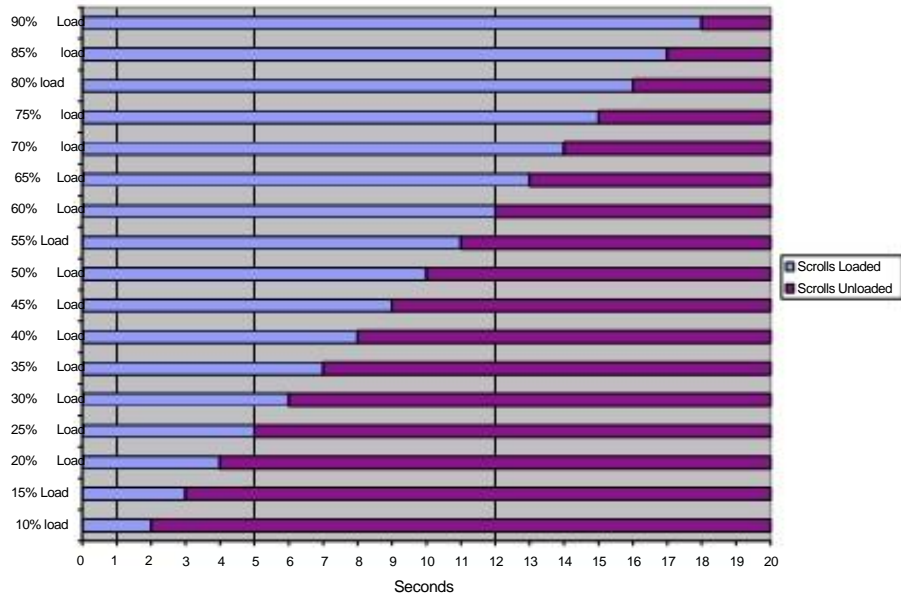

Figure 3 - 20 Second Operating Cycle



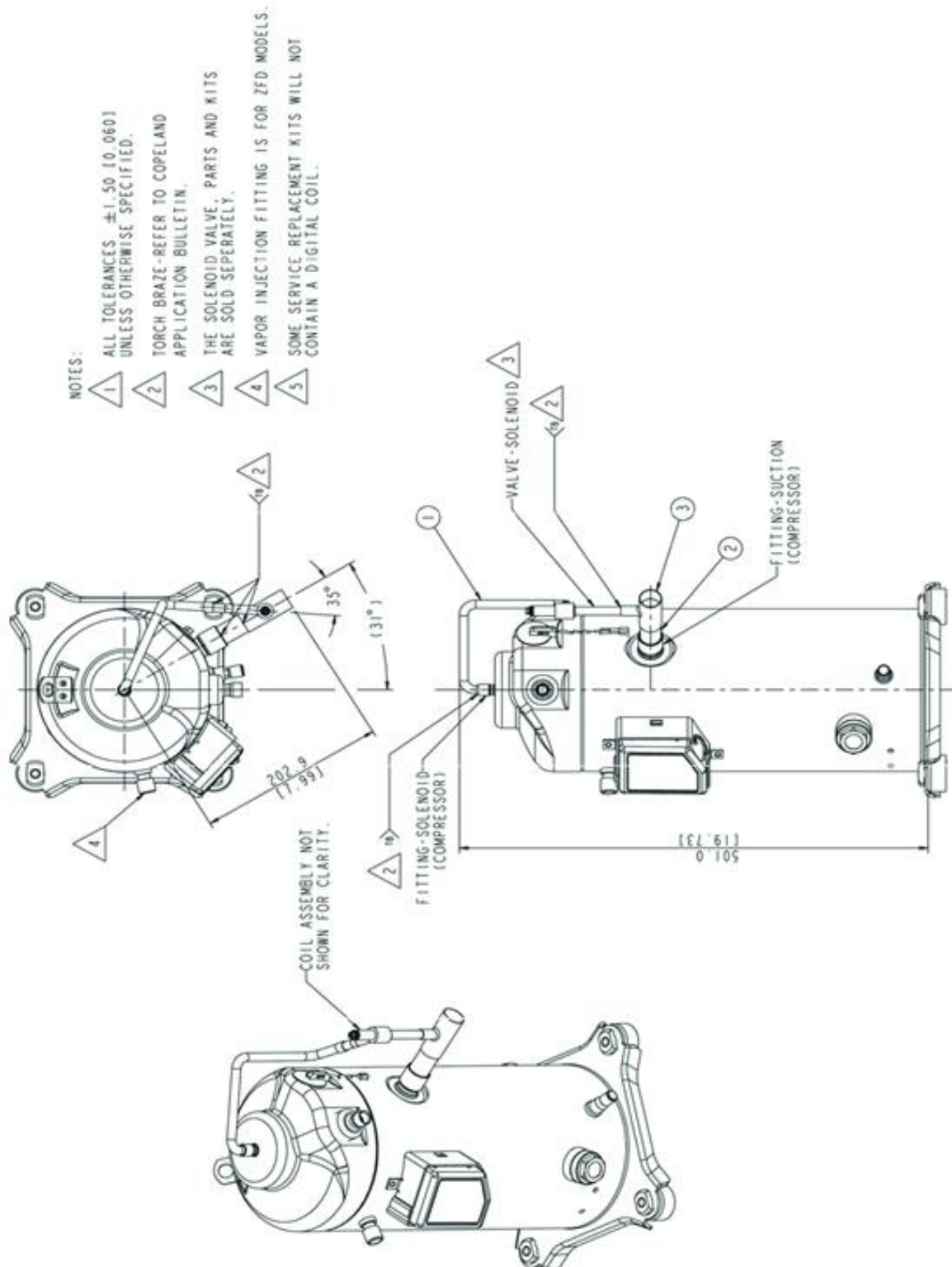

Figure 4 - Injection Assembly Diagram with Sweat Connections

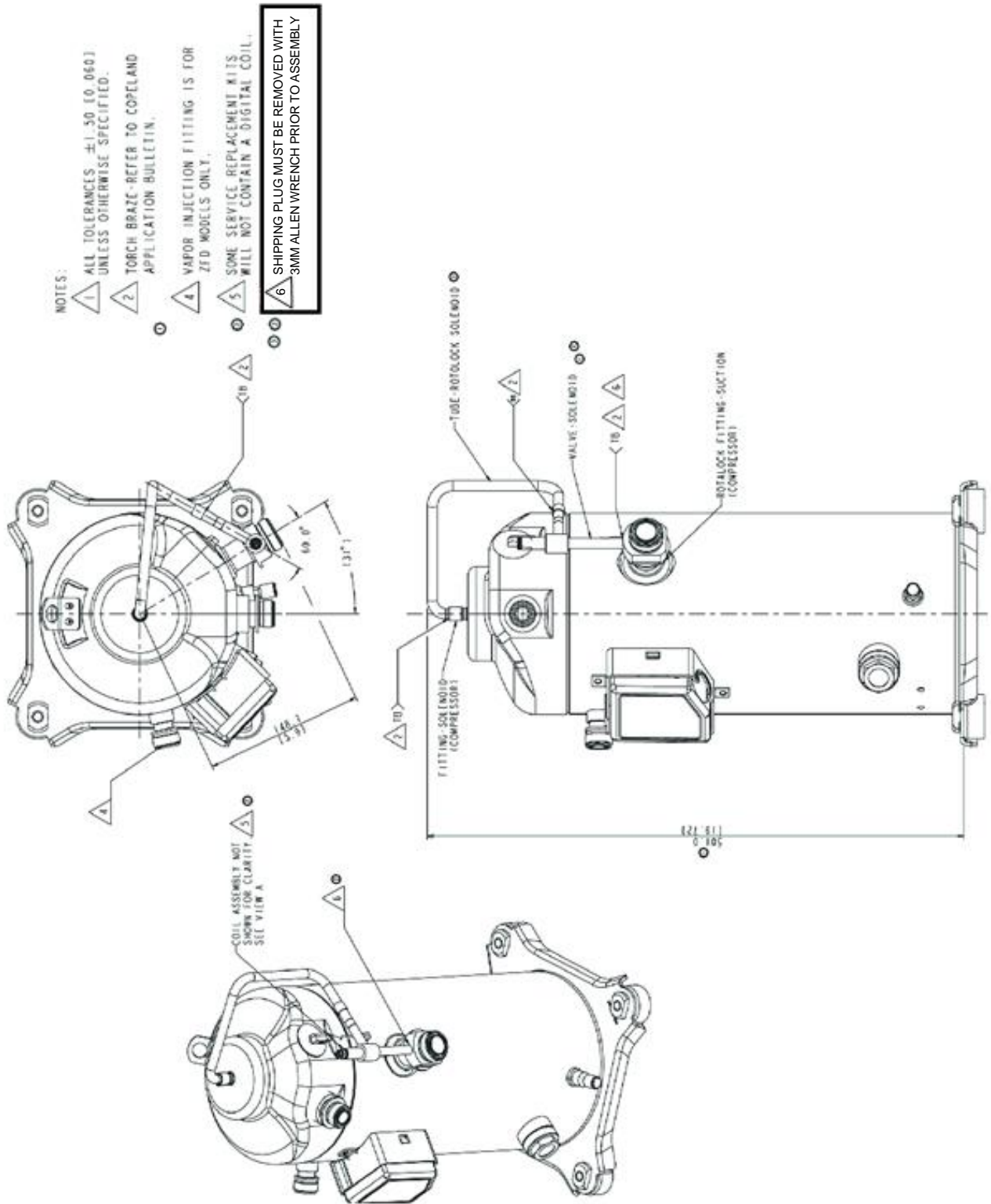

Figure 5  
Injection Assembly Diagram with Rotalock Connections

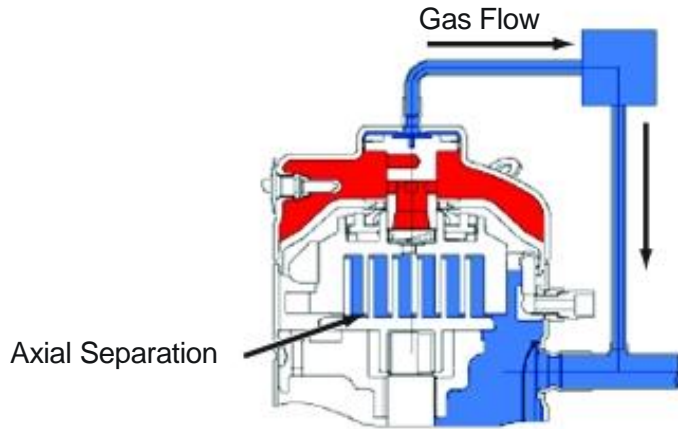

Figure 6  
Unloaded Operation Solenoid Valve Energized (open)

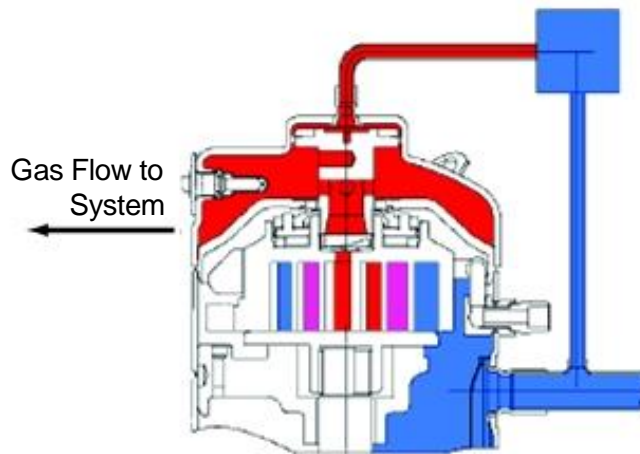

Figure 7  
Loaded Operation Solenoid Valve De-energized (closed)

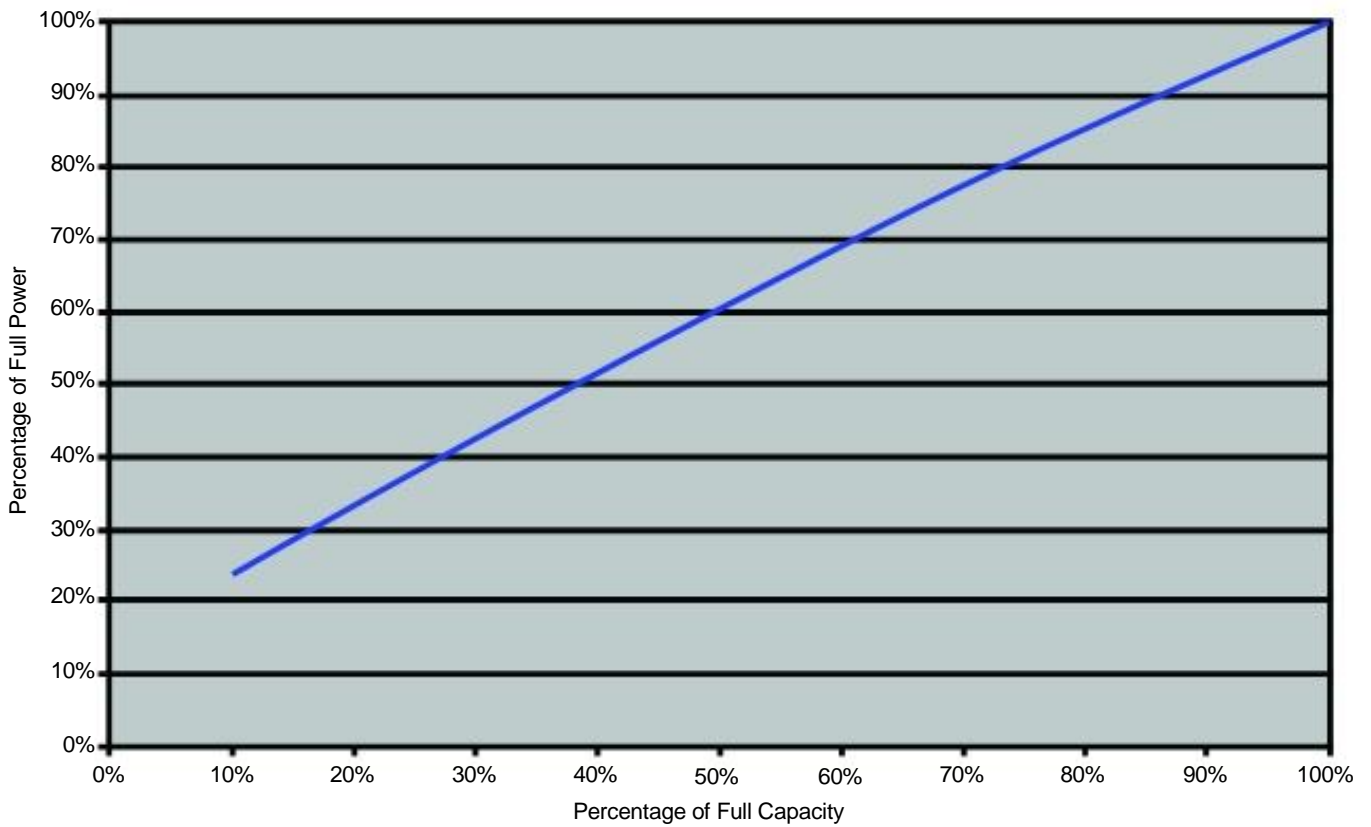

Figure 8  
Typical Modulated Power Reduction

The contents of this publication are presented for informational purposes only and are not to be construed as warranties or guarantees, express or implied, regarding the products or services described herein or their use or applicability. Emerson Climate Technologies, Inc. and/or its affiliates (collectively "Emerson"), as applicable, reserve the right to modify the design or specifications of such products at any time without notice. Emerson does not assume responsibility for the selection, use or maintenance of any product. Responsibility for proper selection, use and maintenance of any Emerson product remains solely with the purchaser or end user.