



A⁴

SERIES

NEW A4 SERIES

L'Alta Gamma di Ronda

THE EXCLUSIVE RANGE OF RONDA



NEW SERIES

A4

RONDA PRESENTA

la nuova linea di cassetti e sportelli
per banchi bar refrigerati **Serie A4**



Ronda presents its new line of drawers
and doors for refrigerated counters

A4 SERIES



SPORTELLO SINGOLO

AX4

A^{X4}

SPORTELLO SINGOLO
SINGLE DOOR

- > **Chiusura magnetica**
Magnetic closure
- > **Cerniera sportelli 5 maglie**
5 Knuckles in total per hinge
- > **Spessore totale 58 mm**
Total thickness 58 mm



Sportelli con apertura 180°
Doors with 180 opening

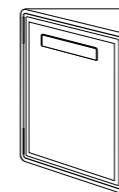

Apertura a sinistra
Left-hand opening



Sportelli predisposti per l'inserimento
della resistenza riscaldante

The door can be fitted with heating wire
Detail installation heating wire

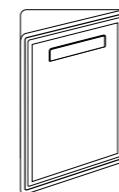

Apertura a destra
Right-hand opening



Possibilità di finitura scotch brite
Scotch brite finishing available on demand



Finishing scotch brite

Finishing standard

STUDIATO PER LE BASSE TEMPERATURE
STUDIED FOR LOW TEMPERATURES

FORO BANCO DIMENSIONI ESTERNE ED INTERNE
COUNTER HOLE EXTERNAL AND INTERNAL SIZE

	a(+1)	b(+1)	x	y	g	g1	z	s
AX41	442	305	473	335	360	398	50	5
AX42	442	404	473	435	360	398	50	5
AX43	442	442	473	473	360	398	50	5
AX46	442	502	473	533	360	398	50	5
AX47	442	602	473	633	360	398	50	5
AX48	442	702	473	732	360	398	50	5

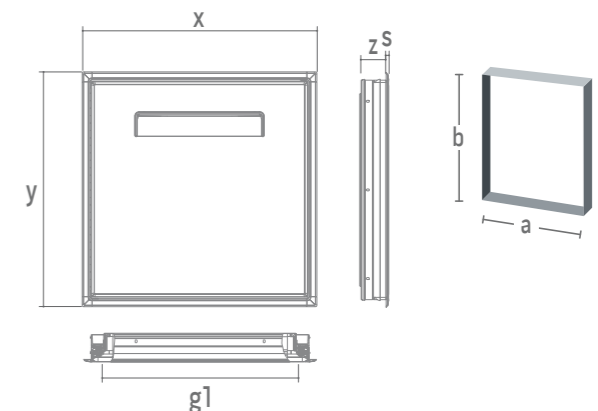

A⁴
SERIES



SPORTELO DOPPIO

A^{L4}

A^{L4}

SPORTELO DOPPIO
DOUBLE DOOR

- > **Chiusura magnetica**
Magnetic Closure
- > **Cerniera sportelli 5 maglie**
5 Knuckles in total per hinge
- > **Spessore totale 58 mm**
Total Thickness 58 mm



Possibilità di finitura scotch brite
Scotch brite finishing available on demand



FORO BANCO **DIMENSIONI ESTERNE ED INTERNE**
COUNTER HOLE EXTERNAL AND INTERNAL SIZE

	a(+1)	b(+1)	x	y	g	g ¹	z	s
AL46	502	878	909	533	758	834	50	5
AL47	602	878	909	633	758	834	50	5
AL48	702	878	909	732	758	834	50	5

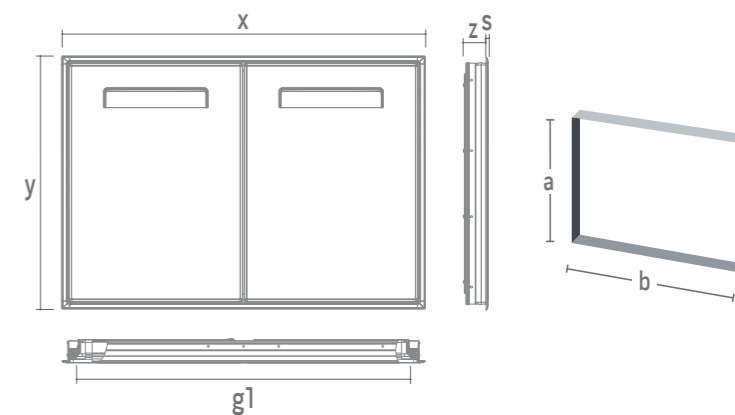

A⁴
SERIES

A^{K4}

CASSETTO SINGOLO
SINGLE DRAWER

- > **Chiusura magnetica**
Magnetic closure
- > **Possibilità di scorrimento standard o telescopico extra corsa (optional)**
Standard or telescopic guides (on request)

Possibilità di finitura scotch brite
Scotch brite finishing available on demand



CASSETTO SINGOLO

A^{K4}



FORO BANCO **DIMENSIONI ESTERNE ED INTERNE**
COUNTER HOLE EXTERNAL AND INTERNAL SIZE

	a(+1)	b(+1)	x	y	e	f	h	u	l	s
AK41	442	255	473	285	459	361	145	192	540	5
AK41C	442	255	473	285	397	361	145	192	478	5
• AK41T	442	255	473	285	459	361	145	192	541	5
AK42	442	305	473	335	459	361	145	242	540	5
AK42C	442	305	473	335	397	361	145	242	478	5
• AK42T	442	305	473	335	459	361	145	242	541	5
AK43	442	404	473	435	459	361	290	341	540	5
AK43C	442	404	473	435	397	361	290	341	478	5
• AK43T	442	404	473	435	459	361	290	341	541	5
AK44	442	442	473	473	459	361	290	380	540	5
AK44C	442	442	473	473	397	361	290	380	478	5
• AK44T	442	442	473	473	459	361	290	380	541	5

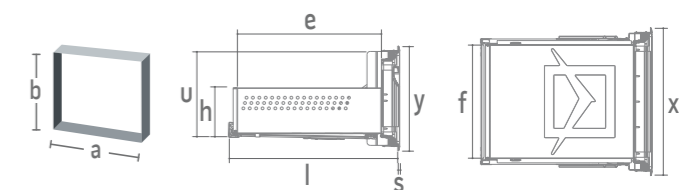

• **VERSIONE CON GUIDE TELESCOPICHE**
TELESCOPIC VERSION

A⁴
SERIES



**CASSETTIERA
A DUE CASSETTI UGUALI**

AM4

A^{M4}

**CASSETTIERA
A DUE CASSETTI UGUALI**
TWIN-DRAWER UNIT

- > **Chiusura magnetica**
Magnetic closure
- > **Possibilità di scorrimento standard o telescopico extra corsa (optional)**
Standard or telescopic guides (on request)

Possibilità di finitura scotch brite
Scotch brite finishing available on demand



FORO BANCO **DIMENSIONI ESTERNE ED INTERNE**
COUNTER HOLE EXTERNAL AND INTERNAL SIZE

	a(+1)	b(+1)	x	y	e	f	h1	h2	u1	u2	l	s
AM42	442	502	473	533	459	361	145	145	192	191	540	5
AM42C	442	502	473	533	397	361	145	145	192	191	478	5
• AM42T	442	502	473	533	459	361	145	145	192	191	541	5
AM43	442	602	473	633	459	361	145	145	242	241	540	5
AM43C	442	602	473	633	397	361	145	145	242	241	478	5
• AM43T	442	602	473	633	459	361	145	145	242	241	541	5

• **VERSIONE CON GUIDE TELESCOPICHE**
TELESCOPIC VERSION

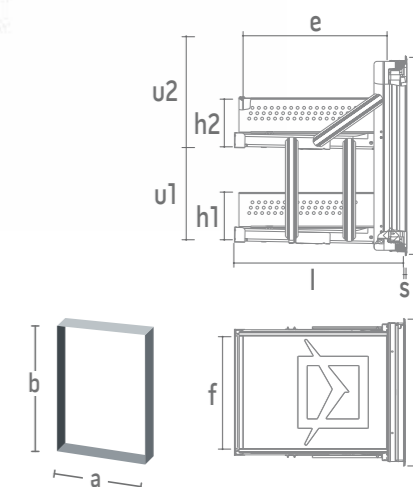

A⁴
SERIES



CASSETTIERA
A DUE CASSETTI DIVERSI

AZ4

A^{Z4}

**CASSETTIERA
A DUE CASSETTI DIVERSI**

DRAWER UNIT WITH TWO
DIFFERENTLY SIZED DRAWERS

- > **Chiusura magnetica**
Magnetic closure
- > **Possibilità di scorrimento standard o telescopico extra corsa (optional)**
Standard or telescopic guides (on request)

Possibilità di finitura scotch brite
Scotch brite finishing available on demand



FORO BANCO **DIMENSIONI ESTERNE ED INTERNE**
COUNTER HOLE EXTERNAL AND INTERNAL SIZE

	a(+1)	b(+1)	x	y	e	f	h1	h2	u1	u2	l	s
AZ41	442	602	473	633	459	361	290	96	342	141	540	5
AZ41C	442	602	473	633	397	361	290	96	342	141	478	5
• AZ41T	442	602	473	633	459	361	290	96	342	141	541	5
AZ45	442	702	473	732	459	361	290	145	342	241	540	5
AZ45C	442	702	473	732	397	361	290	145	342	241	478	5
• AZ45T	442	702	473	732	459	361	290	145	342	241	541	5

• **VERSIONE CON GUIDE TELESCOPICHE**
TELESCOPIC VERSION

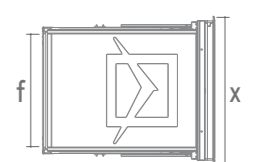
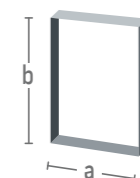
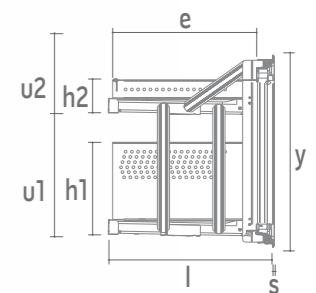

A⁴
SERIES

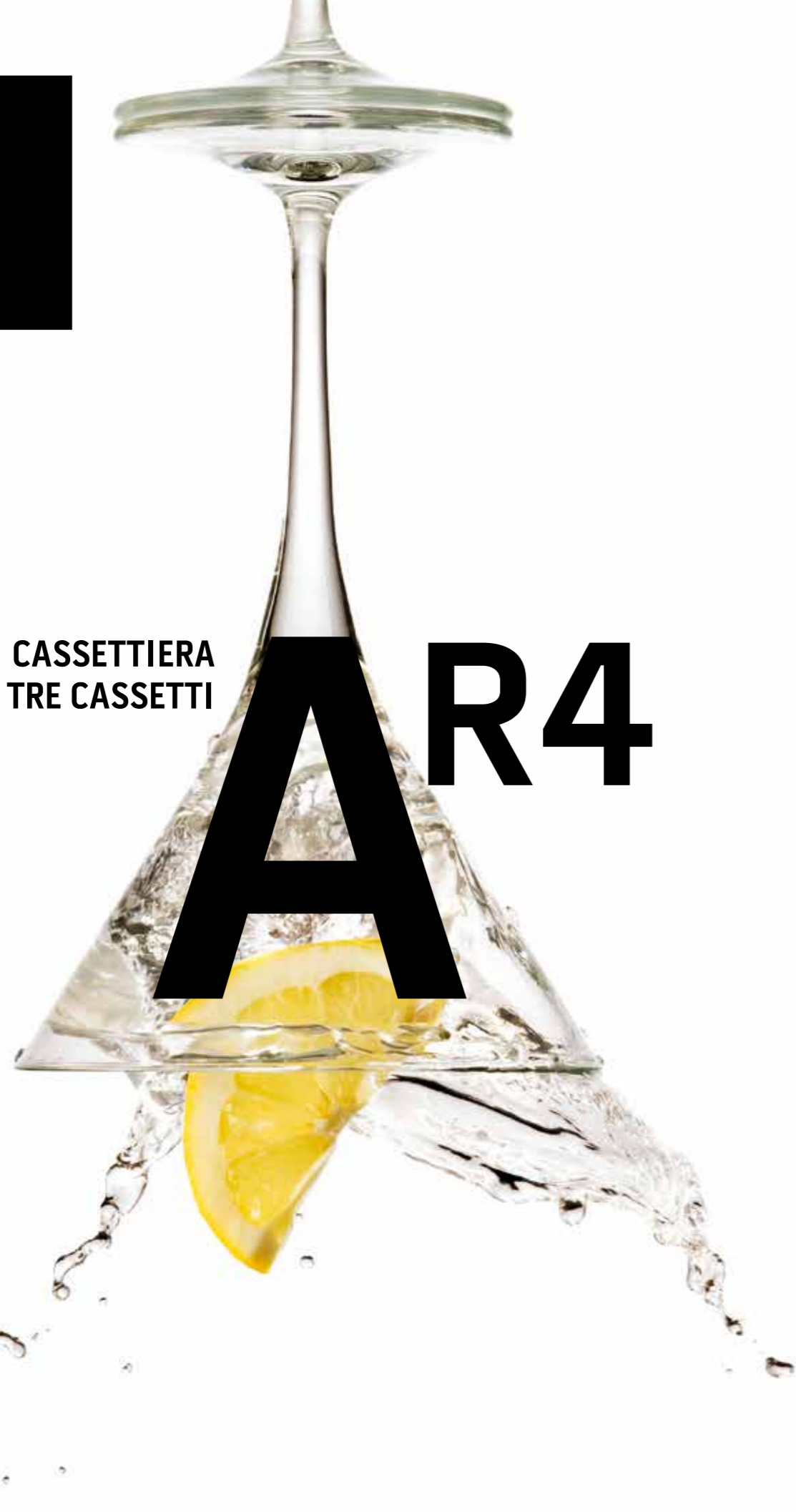

CASSETTIERA
A TRE CASSETTI

AR4

A^{Z4}

CASSETTIERA A TRE CASSETTI
TRIPLE DRAWER UNIT

- > Chiusura magnetica
Magnetic closure
- > Possibilità di scorrimento standard
o telescopico extra corsa (optional)
Standard or telescopic guides (on request)

Possibilità di finitura scotch brite
Scotch brite finishing available on demand



FORO BANCO DIMENSIONI ESTERNE ED INTERNE
COUNTER HOLE EXTERNAL AND INTERNAL SIZE

	a(+1)	b(+1)	x	y	e	f	h1	h2	h3	u1	u2	u3	l	s
AR41	442	602	473	633	459	361	96	96	96	143	143	142	540	5
AR41C	442	602	473	633	397	361	96	96	96	143	143	142	478	5
• AR41T	442	602	473	633	459	361	96	96	96	143	143	142	541	5
AR42	442	702	473	732	459	361	145	96	96	242	143	142	540	5
AR42C	442	702	473	732	397	361	145	96	96	242	143	142	478	5
• AR42T	442	702	473	732	459	361	145	96	96	242	143	142	541	5

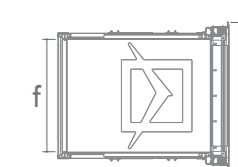
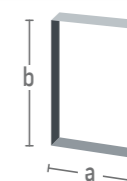
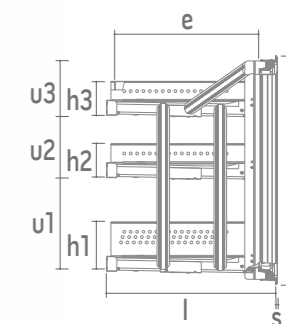

• VERSIONE CON GUIDE TELESOPICHE
TELESCOPIC VERSION

Design, tecnologia e funzionalità sono le note distintive che Ronda, nell'arco di 45 anni ha perseguito, nella progettazione e realizzazione dei suoi prodotti.

Azienda leader nel mercato della produzione di componenti "cassetti, sportelli, vaschette, vasche di lavaggio in acciaio inossidabile" per l'arredamento di bar e strutture di ristorazione.

La produzione dell'azienda, ha conquistato il mercato italiano e i principali mercati europei, contribuendo a diffondere l'eleganza e lo stile tipicamente italiani: oggi quando si parla di bar nel mondo si parla di Italian Style. I prodotti Ronda sono sottoposti a severissime prove di affidabilità perché, oltre alla bellezza e all'ergonomia, gli ambienti della ristorazione richiedono anzitutto resistenza e durata. Per rendere più tecnologico, igienico, facile ed elegante il servizio bar.

Design, technology and functionality are the aims that Ronda has been pursuing for more than 45 year in the planning and realisation of its products.

Ronda is the leading company in the production of stainless steel components "doors, drawers, food containers, sink bowls..." for bar fittings and professional kitchens.

Ronda's quality and design have asserted themselves in the main European markets, spreading worldwide the elegance of the Italian style. All Ronda products are subject to the most severe quality tests as the ho.re.ca sector requires not only ergonomics and elegance, but also resistance and durability.

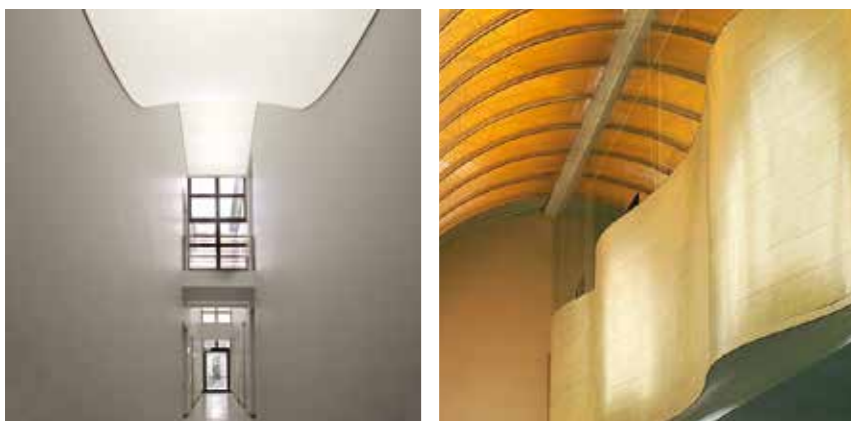

A⁴

LEGENDA
KEY

- (a+1)** Tolleranza consigliata (misure in mm)
(b+1) Suggested tolerance (measurements in mm)
- e - f** Dimensioni interne della cassa
Internal dimensions of the container
- h** Altezza cassa interna
Available internal height
- u** Altezza utile interna
Available internal height
- x - y** Dimensioni esterne della cornice
Dimensions of the front panel including the frame
- l** Profondità totale dell'articolo da filo banco
Total depth of the item from the counter front
- s** Sporgenza esterna da filo banco
External projection from the counter front
- g** Passaggio utile a 90°
Available space at 90°
- gl** Passaggio utile a 180°
Available space at 180°
- z** Profondità cornice da filo banco
Depth of frame from counter front



A⁴

SERIES



Ronda S.p.A.

Via Vegri 83,
36010 Zane (VI) Italy

Tel +39 0445 385600
Fax: +39 0445 385700
E-mail: vendite@ronda.it
E-mail: sales@ronda.it
www.ronda.it