

The OMB is a compressor crankcase oil level protective control ideal for use with Copeland Scroll® models ZF, ZB, ZR and ZS. It is also recommended for Copeland® brand products, Carlyle, Bitzer, and other semi-hermetic compressors.

Features

- Precision oil level measurement for maximum protection
- Easy monitoring with alarm and status lights
- Foam resistant design prevents nuisance trips unlike optical sensor designs
- Contaminant proof operation ensures accurate control
- Only approved oil level control for Copeland Scroll® Compressors
- 5-time lockout feature protects compressor from repeated low oil level condition
- Self-contained unit with oil lever sensor and integral solenoid to manage oil level supply
- Reverse Hall-effect sensor for precise measurement of oil level and protection from sensor magnetic debris contamination
- SPDT output contact for compressor shut-down and alarming
- Easy installation by sightglass replacement
- Adapters suitable for various types of scroll compressors (not required for reciprocating compressors)
- UL Recognized (File Number# MP604)
- Fluorescent floating ball
- Integral sight glass
- Debris retention magnet for reliable operation

Nomenclature example: OMB-JB1 ASC2 24 50/60

OMB	JB1	ASC2 24 50/60
Oil Management Control	JB1 - Junction Box MO1 - Series Relief Connector	Solenoid Coil Model Number, Voltage, Frequency (included)

Ordering Information

PCN	DESCRIPTION
065365	Oil Management Control
065366	OMB-JB1 ASC 2 24/50-60 - STD OMB-MO1 ASC 2 24/50-60 - STD
	Adapters (to attach OMB to Copeland Scroll® compressor for new installation only)
065668	OMB-ACA ADAPTER (3/4" x 14 NPTF) Copeland® Glacier, ZF, ZS, ZB
065667	OMB-ACB ADAPTER (1 1/8" x 12 UNF) Copeland® A/C ZR
066077	OMB-ACD ADAPTER (1 1/4" x 12 UNF) Copeland® A/C Summit Series
066078	OMB-ACE ADAPTER (1 3/4" x 12 UNF) Copeland® Specter Series
063521	OMB-AUA Copeland® 6D Semi-Hermetic
065982	OMB-ASA Carlyle Compressors DA, DR, 5F, 5H, 06D and 06E
	Service Parts
048638	Inlet Flare Screen
020877	Sight Glass O-Ring
064812	Mounting O-Rings (3 pieces)
049191	KS-30112 Solenoid Repair Kit



R-410A

Specifications

- Maximum working pressure: 640 psi
- Solenoid MOPD: 350 psi
- Supply voltage: 24 V AC, 50/60 Hz
- Solenoid coil: ASC 2L 24 V AC, 50/60 Hz
- Current consumption: 0.6A
- Time delay for low level signalling: 5-10 seconds
- Time delay for after setpoint recovery: 5-10 seconds
- Alarm delay time: 120 seconds
- Alarm switch: SPDT
- Alarm contact rating: 10A @ 125V; 5A @ 220 V AC 50/60 Hz
- Refrigerant compatibility: HFC, HCFC, CFC
- Oil temperature: 180°F Max.
- Storage and transport temperature: 140°F Max.
- Operating ambient temperature: 120°F Max.
- Oil supply fitting: 1/4" Male SAE
- UL/CUL file number: SA8547
- Transformer VA requirements* 25"

*NOTE: Field supplied transformer should always be of the same primary voltage as the electrical supply system.

Dimensional Data

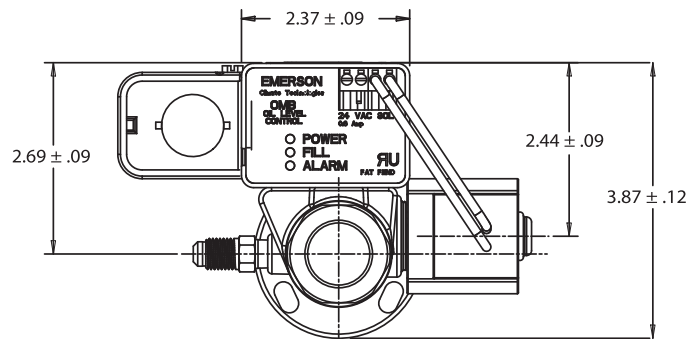

Unit must be mounted horizontally for correct operation.