

Electronic Power Modules FSP control the speed of condenser fan motors in commercial refrigeration and air-conditioning systems. The necessary input signal of 0...10 V depending on condensing pressure can be generated by the optional Control Module FSE, or other electronic controllers.

Features

- Can be used in combination with **ALCO FSE, EC2, EC3** and other electronic controllers which provide a 0...10 V output signal for condensing pressure control
- Energy saving due to improved cooling efficiency
- Reduced fan noise level during low ambient temp. conditions
- Improved overall performance of cooling system
- Versions for 1- and 3-phase Motors
- Short start impulse to overcome friction and windmilling
- Easy installation with cables for power supply and motor connection factory wired
- IP 67 protection for outdoor mounting
- CE marking (EMC, LVD)

Options

- FSE Control Module for pressure input
- Cable assemblies



**FSP
Power Module**

Introduction

The **FSP** Power Modules together with **FSE** Control Modules are designed to control the speed of fan motors depending on condenser pressure. Optional FSP can be driven by other controllers which supply the 0...10V signal, e.g. EC3-75x from ALCO. The **FSP** can be used in air-cooled condensers, air-cooled condensing units and air-conditioning units.

Using variable fan speed control offers the following benefits for your application (see figure below):

Head pressure can be kept high enough to ensure proper operation of the expansion valve, and hence, sufficient mass flow through the expansion valve to feed the evaporator. This maintains the required cooling capacity.

Compared to on-off cycling of fan motors during low ambient conditions the continuous fan control maintains lowest possible head pressure, see figure below. This improves COP of compressors along with the according energy savings, more stable suction pressure and a positive impact on the overall performance of the cooling system.

The noise level of fan motors can be reduced to a minimum by avoiding permanent on/off cycling.

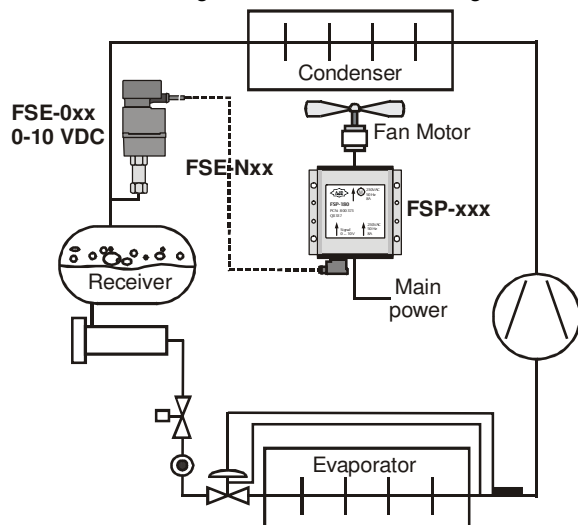

FSP have EMC-filters installed and comply with EC-Directive 89/336/EC (electromagnetic compatibility requirements of the European Community).

Condensing pressure

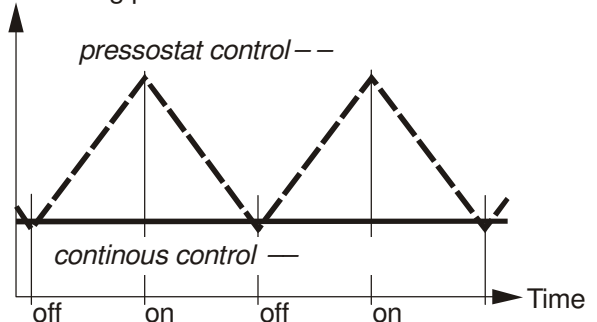

Operation

The behaviour of **FSP** together with **FSE** can be described by the control diagram figure right. The top curve describes the fan speed at decreasing, the lower curve at rising pressure. At high condensing pressure fan is running with maximum speed (top right). In the proportional range of the curve fan speed is decreased with pressure. If the pressure falls below the specified limit the fan is switched off (cut-off point in the curve).

A large hysteresis is built-in to prevent fan cycling at this point. Pressure must increase by approximately 1 bar before fan restarts. A short start pulse helps fan to overcome friction or windmilling before it supplies the proportional value.

Along the proportional range the fan speed varies between 20% and 100%, 3-phase motors respectively 30% and 100% for single phase motors.

Control Diagram

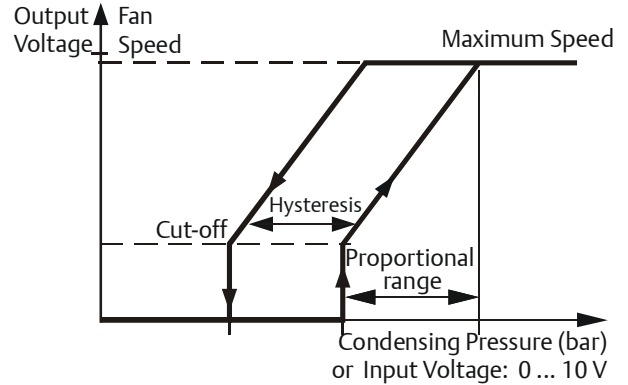

Electromagnetic Compatibility

FSP series is CE-marked and conforms to the requirements of EC-Directive 89/336/EEC as long as it is correct installed according to the operation instructions. It should be considered that when two or more EMC compliant components are combined in the same system the resulting system may not be compliant. The FSP was tested for emissions according EN 55014-1:2000, EN 61000-4-4, EN 61000-4-5, EN 61000-4-6 and EN50082-1.

Motor

The performance of fan motors used with the **FSP** Power Module can vary. An important factor is the ratio between starting- and nominal current. The start-up current of motors is much higher than the nominal current at full speed.

Single phase motors with Steinmetz capacitor typically consume 20% more current during partial speed than the specified nominal current. The cooling of fan motors is less efficient at low speed. Both effects together can warm-up motors more than under full load conditions. It is therefore imperative to ensure that motor protection is wired correct.

Important note: FSP should only be used with fans released by manufacturer for speed control by means of phase-cut (see the respective fan motor datasheet).



FSE-02S

Single- and 3-phase Motors

Single phase Motors very often have the same mechanical construction than 3-phase motors. The main power is connected to 2 of the 3 terminals. A capacitor is used to generate the phase-shift on the 3rd terminal (Steinmetz wiring). Due to this unsymmetrical construction principle single phase motors have a much lower start-up torque compared to 3-phase motors.

Paralleling of Fan Motors

FSP Power Modules allow paralleling of several fan motors, as long as the sum of the motor currents does not exceed the maximum operating current of the module.

Paralleling of Fan Motors

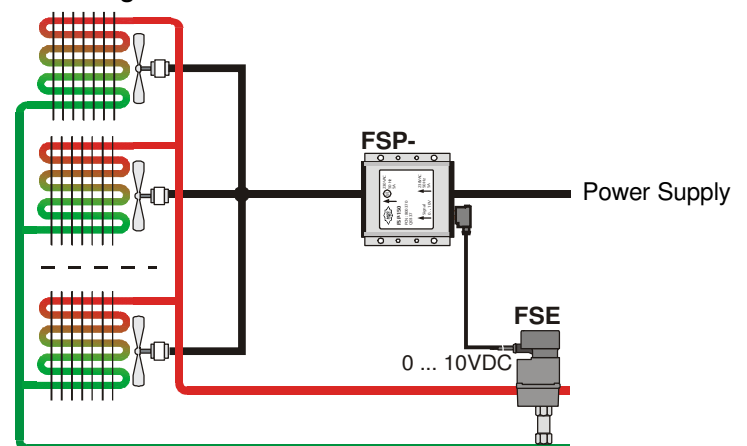

Product Combinations

Selection

1. Select a **Power Module FSP** by the total maximum operating current and phases of condenser fan motors.

2. Select a **Control Module FSE** based on the pressure requirements of the refrigerant used:

- FSE-01S** for R 134a
- FSE-02S** for R 22 / R 407C / R 507
- FSE-03S** for R 410A

3. Select a **Cable Assembly**

- a) for connection of FSE to FSP:
 - 3 lengths: (1.5 - 3.0 - 6.0 m) and
 - 2 temperatures: **FSE-N**: -25 ... +80 °C
 - FSE-L**: -50 ... +80 °C
- b) for use with an Electronic Controller with 0...10V signal output (EC3-75x, EC3-93x or other):
 - 3 lengths (1.5 - 3.0 - 6.0 m) and
 - 1 temperature: **FSP-L**: -50 ... +80 °C

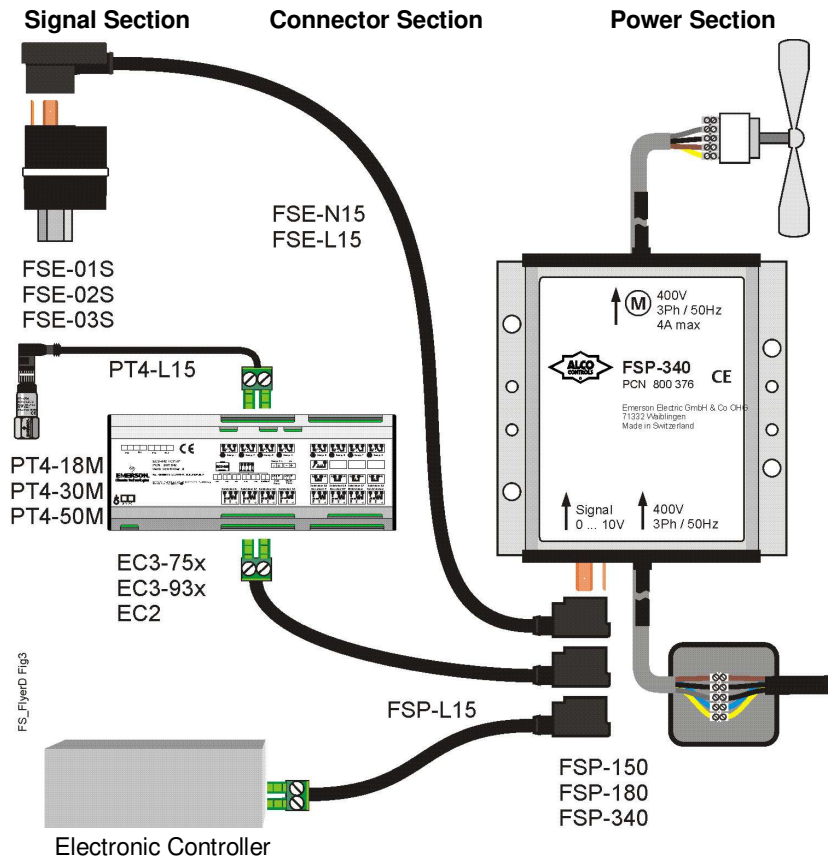

Selection Chart Power Modules FSP

Type	Part No.	Supply Voltage	Current Range (A)	Max. Start Current, max 1 sec (A)	Power Supply Cable Length (mtr)	Motor Cable Length (mtr)	Wire Diameter	Weight (g)
FSP-150	800 370	230V / 50Hz	0,3 - 5	15 A	1,5	0,75	3 x 1 mm ²	1 050
FSP-180	800 373		0,3 - 8	24 A				1 050
FSP-340	800 376	400V / 3 / 50Hz	0,3 - 4	12 A				5 x 1 mm ²

Selection Chart Control Modules FSE

Type	Part No.	Refrigerants	Adjustment Range P _{cut} (bar)*	Cut-off Pressure factory set (bar)	Test Pressure	Pressure Connection	Weight (g)
FSE-01S	804 701	R 134a	4 ... 12.5	7.8	30 bar	7/16" -20 UNF female	125
FSE-02S	804 706	R 22, R 407C, R 404A, R 507	10 ... 21	15.5	36 bar	7/16" -20 UNF female	125
FSE-03S	804 711	R 410A	12 ... 28	20.4	48 bar	7/16" -20 UNF female	150

* P_{cut} = Cut-off pressure at which fan is switched off / lower end of proportional range; see control diagram on page 2

Selection Chart Cable Assemblies for connection to FSE Control Module

Temperature Range -25 to 80 °C / no UL		Temperature Range -50 to 80 °C / UL appr.		Length (mtr.)	Weight (g)
Type	Part No.	Type	Part No.		
FSE-N15	804 680			1,5	80
FSE-N30	804 681			3,0	130
FSE-N60	804 682			6,0	220

for connection to EC2, EC3 and other controllers

	FSP-L15	804 693	1,5	
	FSP-L30	804 694	3,0	

D A T A S H E E T

FSP-L60	804 695	6,0	
----------------	----------------	-----	--

Accessories

Order instructions

For use with EC2-5xx , EC3-75x, EC3-93x and other Controllers

Power Module FSP and cable assembly FSP-Lxx should be used:

Example: FSP-180 Part No. 800 373
 + cable assembly FSP-L15 Part No. 804 693

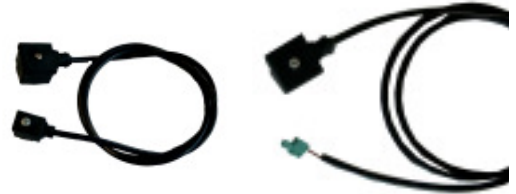

FSE-N15

FSP-L15

For use with FSE-0xx Control Modules

always select

Control Module FSE-0xx,
 Power Module FSP-xxx
 Cable Assembly FSE-Nxx for standard temperature or FSE-Lxx for low temperature range and UL approval.

The table below shows typical examples for refrigeration or air-conditioning applications.



FSE-02S

Selection Chart for Standard Product Sets with FSE Control Modules

Refrigerant	Maximum Motor Rating					
	Single-phase 230VAC 5 Amps		Single-phase 230VAC 8 Amps		3-phase 400V/3/50 4 Amps	
	Type	Part No.	Type	Part No.	Type	Part No.
R 134 a	FSE-01S	804 701	FSE-01S	804 701	FSE-01S	804 701
	FSP-150	800 370	FSP-180	800 373	FSP-340	800 376
	FSE-N15	804 680	FSE-N15	804 680	FSE-N15	804 680
R 22 / R 407C / R 507	FSE-02S	804 706	FSE-02S	804 706	FSE-02S	804 706
	FSP-150	800 370	FSP-180	800 373	FSP-340	800 376
	FSE-N15	804 680	FSE-N15	804 680	FSE-N15	804 680
R 410 A	FSE-03S	804 711	FSE-03S	804 711	FSE-03S	804 711
	FSP-150	800 370	FSP-180	800 373	FSP-340	800 376
	FSE-N15	804 680	FSE-N15	804 680	FSE-N15	804 680

Name Scheme FSP Power Modules

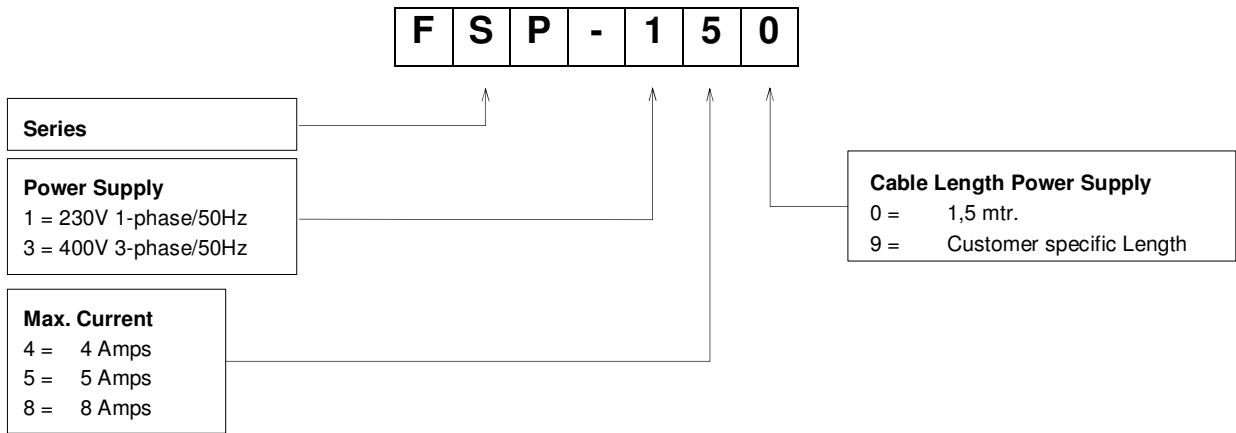

Name Scheme FSE Control Modules

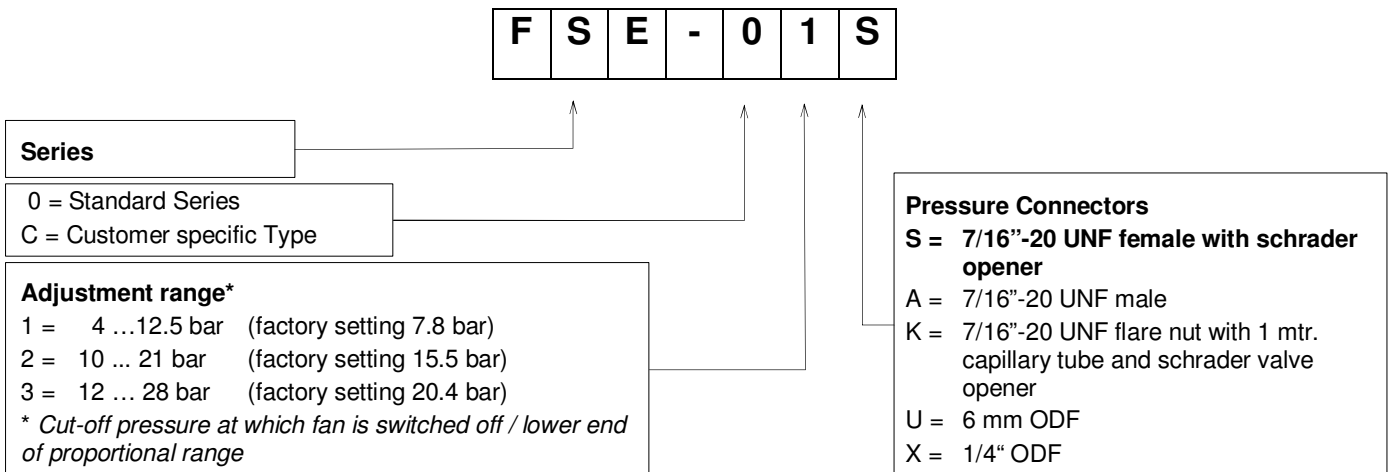

Name Scheme Cable Assemblies

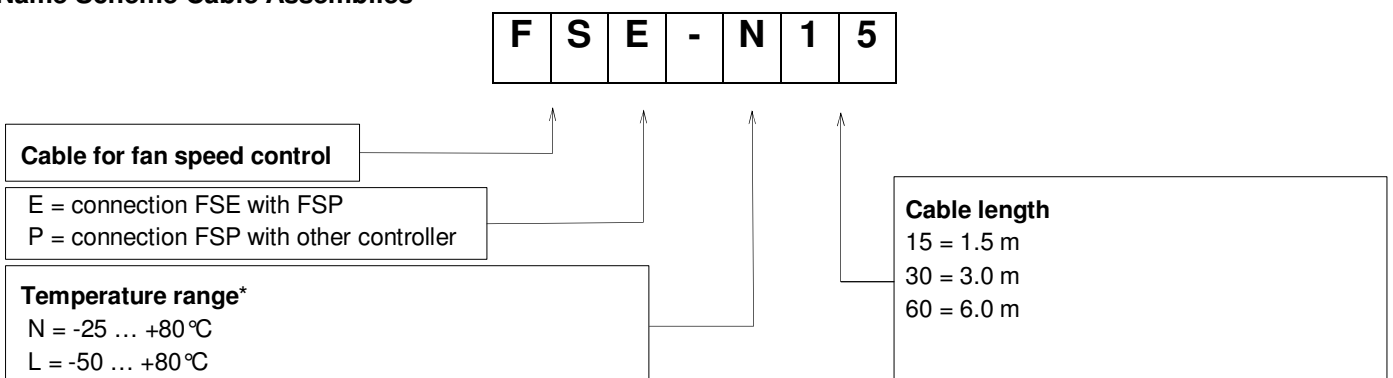

Technical Data FSP

Temperature range	
Storage and transportation	-40°C ... 70°C
Operation	-20°C ... 65°C
Material housing	Aluminum with plastic ends, completely molded with a 2 component Polyurethane casting compound. Resistant against common refrigerant oils.
Mounting	Direct with screws or DIN-rail with mounting clips

Signal Input Voltage	0 ... 10 VDC
Supply Voltage	FSP-150/-180: 230V 1-phase/50Hz FSP-340: 400V 3-phase/50Hz
EMC Compatibility	EN 55014-1:2000 EN 61000-4-4 EN 61000-4-5 EN 61000-4-6 EN 50082-1
Protection class (IEC529/EN 60529)	IP 67
Weight	FSP-150/-180: 1,0kg FSP-340: 1,8kg

Dimensions (mm)

FSP-150 / FSP-180

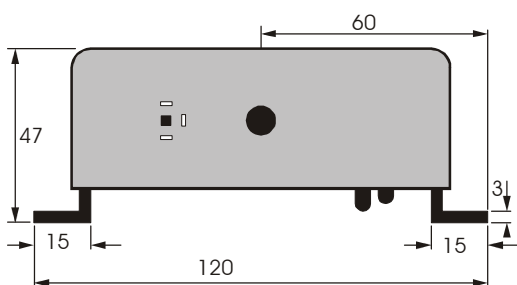
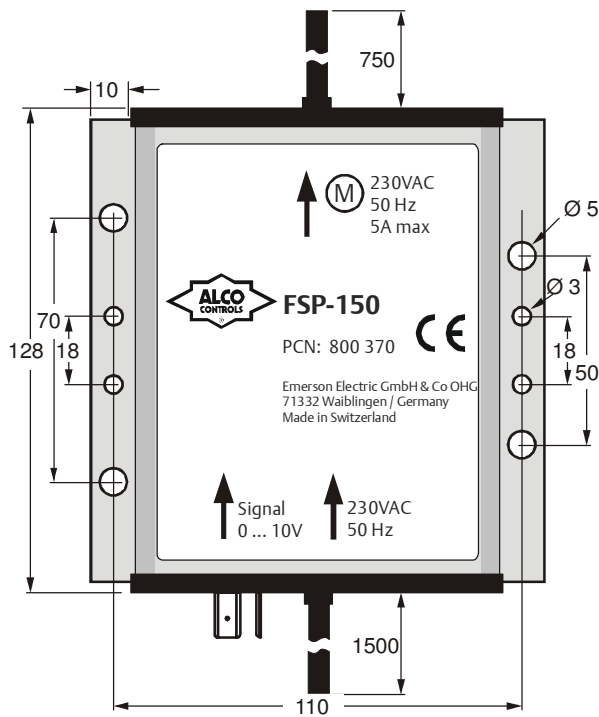

FSP-340

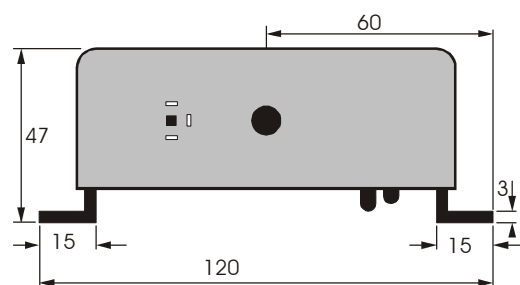
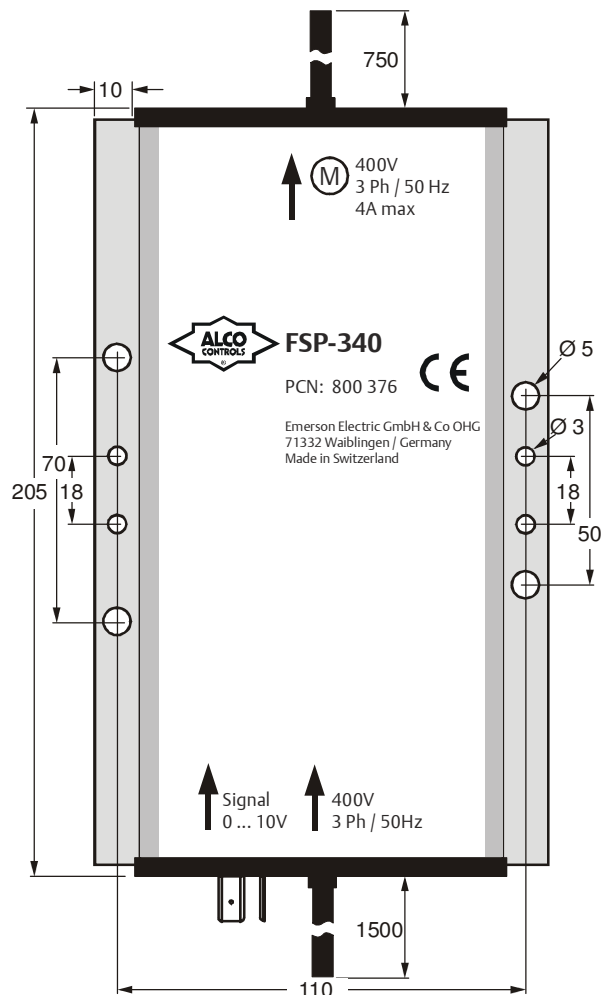

D A T A S H E E T

Technical Data FSE

Supply Voltage	10V; supplied by FSP Power Module	Pressure connection FSE-01S and FSE-02S FSE-03S	Brass Stainless Steel
Operating current 0...10 VDC output	max. 1 mA	Max. operating pressure PS	FSE-01_: 27bar FSE-02_: 32bar FSE-03_: 43bar
Medium compatibility	HFC, HCFC, POE-, synthetic and mineral oils	Temperature Range Storage and transportation Operation	-30° ... +70°C -20° ... +65°C
Protection class (IEC529/EN 60529)	IP 65	Materials Housing cover	PA

Dimensions (mm)

FSE-01S / FSE-02S

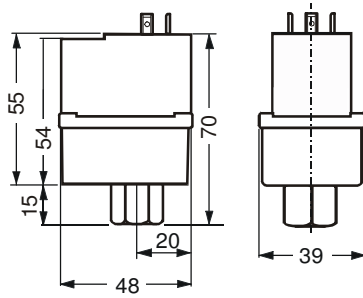

FSE-03S

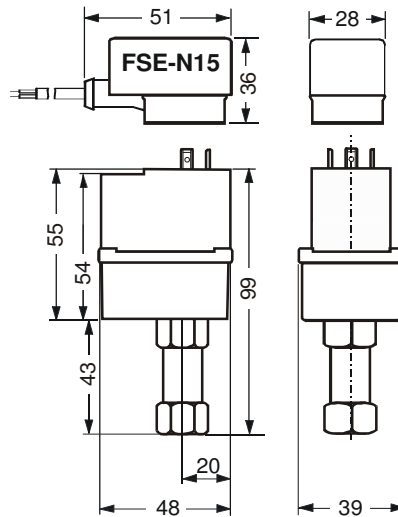

EMERSON is not to be held responsible for erroneous literature regarding capacities, dimensions, applications, etc. stated herein. Products, specifications and data in this literature are subject to change without notice. The information given herein is based on technical data and tests which EMERSON believes to be reliable and which are in compliance with technical knowledge of today. It is intended only for use by persons having the appropriate technical knowledge and skills,

at their own discretion and risk. Since conditions of use are outside of EMERSON'S control we can not assume any liability for results obtained or damages occurred due to improper application. Our products are designed and adapted for fixed locations. For mobile applications failures may occur. The suitability for this has to be assured from the plant manufacturer which may include making appropriate tests. This document replaces all earlier versions.

		Phone:	Fax:
Emerson Electric GmbH & Co OHG	Benelux	+31 (0)77 324 0 234	+31 (0)77 324 0 235
ALCO CONTROLS	Germany, Austria & Switzerland	+49 (0)6109 6059 -0	+49 (0)6109 6059 40
Postfach 1251	France, Greece, Maghreb	+33 (0)4 78 66 85 70	+33 (0)4 78 66 85 71
Heerstraße 111	Italia	+39 02 961 781	+39 02 961 788 888
D-71332 Waiblingen	Spain & Portugal	+34 93 41 23 752	+34 93 41 24 2
Germany	UK & Ireland	+44 (0) 1635 876 161	+44 (0) 1635 877 111
Phone ...49-7151-509-0	Sweden, Denmark, Norway & Finland	+49 (0)2408 929 0	+49 (0)2408 929 528
Fax ...49-7151-509-200	Eastern Europe & Turkey	+49 (0)2408 929 0	+49 (0)2408 929 525
	Poland	+48 (0)22 458 9205	+48 (0)22 458 9255
www.emersonclimate.eu	Russia & Cis	+7 495 981 9811	+7 495 981 9816
	Balkan	+385 (0) 1560 38 75	+385 (0) 1 560 3879
	Romania	+40 364 73 11 72	+40 364 73 12 98
	Ukraine	+38 44 4 92 99 24	+38 44 4 92 99 28